



**MADE FROM BILLETS**



**GREEN FRIENDLY  
ALUMINIUM**



**An ISO 9001:2008 CERTIFIED  
COMPANY**



Registered Office

# **TALCO ALUMINIUM COMPANY**

**An ISO 9001:2008 Certified Company**

**MANUFACTURER OF ALUMINIUM EXTRUSION PROFILES**

Regd. Office: # D85/1, GNT Road, Ponniammanmedu, Madhavaram Chennai - 600 110

(Landmark: Near Madhavaram Flyover & OPP. Road of HP PETROL BUNK)

PH. +91-44-23468559 / 23468533 / 23468907 / TELEFAX: 23468906

E-mail: [talcochennai@talco.in](mailto:talcochennai@talco.in)



# TALCO ALUMINIUM COMPANY

**MANUFACTURER OF ALUMINIUM EXTRUSION PROFILES  
AN ISO 9001:2008 CERTIFIED COMPANY**



Regd. Office: D85/1, GNT Road, Ponniammanmedu, Madhavaram Chennai - 600 110  
(Landmark: NEAR MADHAVARAM BYEPASS BRIDGE & OPP. HP PETROL BUNK)  
PH. 044-23468559/23468533/23468907, TELEFAX: 044-23468906

E-mail: [talcochennai@talco.in](mailto:talcochennai@talco.in)



Dear Sir,

**Sub: INTRO FOR ALUMINIUM EXTRUSION PROFILES - REG**

We are happy to know that you are one among the few to use good quality Aluminium Extrusion. We feel immense pleasure while introducing ourselves as Manufacturer of Aluminium Extrusion Profiles / Section.

**TALCO ALUMINIUM COMPANY.** (TALCO) is one of the leading Aluminum Extrusion Companies in the industry today. We are known in the industry for having a strong commitment to excellence, growth, and innovation. TALCO has Country's Latest Technology Extrusion plant with 2 Presses of 900 MT Capacity along with modern handling equipment to produce Quality Fine Extrusions (as per IS-733:5082:1285) that are manufactured from high-quality billets made out of in-house metal foundry and offer the widest range of shapes and alloys tested using Advanced Technology of Optical Emission Spectrometer.

TALCO's management staff has a combined extrusion experience that spans for over 35 years. Our company's management team consists of technically skilled individuals who have been working with the top aluminum manufacturers in the business.



All our employees pride themselves in delivering products that meet the standards of both our customers and the industry.



**Quality accreditations**

*ISO 9001:2008 Quality Management System,  
NSIC Registered  
Railways Approved Vendor  
SSI*

**Various applications of Extrusions**

*Transport  
Industrial  
Architectural  
Consumer durables  
Electrical*

Because of the trust of our customers, the expertise of our employees, and the quality of our products, TALCO is proud to be a very active member of the aluminum industry. We assure you that all your extrusion orders will be promptly delivered, and that customer service representatives will be more than happy to answer any questions you may have.

To learn more about our products and services, feel free to contact us @ [talcochennai@talco.in](mailto:talcochennai@talco.in)



***Aluminium – Environment Friendly Future Metal***





## **Vision**

“To be a premium Metals major, with a passion for excellence”

## **Mission**

To relentlessly pursue the creation of Superior Customer Value by exceeding customer expectations profitably and by strict quality standards.

## **Values**

**Integrity** Honesty in every action.

**Commitment** Doing Whatever it takes to deliver, as promised.

**Passion** Missionary zeal arising out of an emotional engagement with work

**Seamlessness** Thinking and working together to meet the requirements.

**Speed** Responding to customers with sense of urgency.

## TALCO Quality Policy

**QUALITY** is the cornerstone of our Mission, which being customer-oriented, is committed to excellence and cost effectiveness.

Quality lies in continuous improvement and in redesigning systems, processes and practices to satisfy customer needs and expectations. It extends to manufacturing, maximising operational efficiency, capacity utilisation and productivity. It involves the integration of human resources, a key to teamwork.

The Objectives of Quality Policy are:

1. To meet the expectations of customers, and improve response time.
2. To ensure reliable and consistent customer service
3. To provide value for money and to be internationally competitive
4. To choose and associate with suppliers to ensure high quality of inputs; through proactive interaction with them, to secure their participation in our quality improvement process
5. To establish a healthy system for quality assurance and improvement, with emphasis on inprocess control in order to ensure error prevention. **Do things right the first time**
6. To formulate quality goals for all functions and foster teamwork.
7. To satisfy “internal customers” as a means to external customer satisfaction.
8. To educate, motivate and involve employees in the fulfillment of the quality.



**ISO 9001 : 2008** Quality Management System

### Key Objectives of TALCO Quality Policy

- |  |  |
|--|--|
| • Complete Customer Satisfaction       | • System for QA & Improvement            |
| • Formulate Quality Goals              | • Satisfy Internal Customer requirements |
| • Unmatched Value                      | • Involve every employee                 |
| • Choose Suppliers on Quality Criteria | • Reliable & Consistent Customer Service |

## METALLURGICAL AND MECHANICAL DATA AND TOLERNCES ALLOY EQUIVALENTS TABLE

IS India (New)	(BS U.K or I.S.(OLD )	(AA) U.S.A	(AICAN) Canada	DIN Germany	ASTM	(AFNOR) France
<b>63401</b>	<b>E91E</b>	<b>6101</b>	D50S	E-AI-99.5 SI-0.5	GS 10 B	-
<b>63400</b>	<b>HE-9</b>	<b>6063</b>	50S	ALMG SI 0.5	GS 10 A	A-SG
<b>64430</b>	<b>HE-30</b>	<b>6351</b>	B51S	ALMG SII	6351	6081(NP)

## TEMPER DESIGNATION TABLE

INDIA / U.K	U.S.A / CANADA	ISO TEMPER	Description of designation
M	F	F	As Fabricated, as manufactured or as cast
-	T3	TD	Solution heat- treated, and cold worked
W	T4	TB	Solution heat-treated, naturally aged and amenable to artificial ageing
P	T5	TE	Artificial aged or precipitation heat-treated
WP	T6	TF	Solution heat- treated & precipitation heat treated

# TALCO ALUMINIUM COMPANY

## INDEX BY APPLICATION

<b>PART 1 - BARS, RODS &amp; TUBES</b>	
FLAT BARS	1
ROUND RODS	2
SQUARE TUBE	2
SQUARE ROD	3
ROUND PIPE	3
FLUTED ROUND PIPE	4
RECTANGULAR TUBE/RACEWAYS	5

<b>PART 2 - STRUCTURAL &amp; ARCHITECTURAL</b>	
EQUAL ANGLE	6
UNEQUAL ANGLE	6
FLUTED ANGLE/CLEAT ANGLE	7
CHANNELS-SQUARE FILLET TOES	8
CHANNELS-ROUND FILLET TOES	8
SINGLE CHANNEL	8
DOUBLE CHANNEL	9
C CHANNEL	9
TEE SECTION	9
GRILL FRAME OR F SECTION	10
GEAR SECTION	10
LADDER /FLUTTED LADDER /MULLION STEP	11
FLUTTED RECT TUBE / LADDER STEP	12
GLAZING CLIP	13
SPL GLAZING CLIP / ADAPTER CLIP	13
<b>DOOR &amp; PARTITIONS</b>	
1.) SINGLE GROOVE (SP)	14
2.) DOUBLE GROOVE (DP)	14
3.) DOOR TOP	15
4.) DOOR VERTICAL	15
5.) DOOR HANDLE	15
5.) DOOR MIDDLE SINGLE GROOVE	16
6.) DOOR MIDDLE DBL GROOVE	16
7.) DOOR BOTTOM	16
8.) DOOR BOTTOM - 12 MM	17
9.) GLAZING PLATE	17
10.) DOOR FRAME	17
11.) LOUVER SECTION	18
<b>WINDOWS FRAME / SUB FRAME</b>	18
12 MM SERIES	19
15 MM SERIES	20
18 MM SERIES	21
20 MM SERIES	22-25
25 MM SERIES	26-29

<b>PART 2 - STRUCTURAL &amp; ARCHITECTURAL</b>	
OPENABLE/CASEMENT WINDOW - H SECTION	30
MULLION SECTION	30
34 MM SERIES WINDOW	31
40 MM SERIES WINDOW	32-33
45 SERIES WINDOW	34-35
CURTAIN WALL SECTION	37-42
NORTHLIGHT GLAZING BAR & SHOE PLATE	43
KITCHEN CABINET SECTION	44
SPL KITCHEN CABINET SECTION	44
SHOWCASE SECTION	45

<b>PART 3 - MOULDINGS &amp; TRANSPORT</b>	
HALF ROUND BEADING	46
FLAT ROUND EDGE	46
SHOW BEADING	46
RUBRAIL / RUBY BEADING	46
KEYGOLA	47
FOOT BOARD BEADING	47
1 1/2" STEP EDGE	48
2 1/4" STEP EDGE / ROOF LATERAL	48
J WATER CHANNEL	48
WIRING CHANNEL	49
SHOW BEADING - 5"	49
SPL BUS WINDOW H	49
TVS WATER CHANNEL	50
TIE BAR/ VOLVO/ DCM E SECTION	50
MAZDA & DBL LEG MAZDA BEADING	51
FLUTED CHANNEL	51
GRILL BEADING	51
DCM E BEADING/ WINDOW FRAME	52
VIPER H SECTION/ MICRO E SECTION	52
VOLVO BEADING	53
DCM SHOW BEADING	53
WALL FACING	53
SMALL HITECH BEADING	53
SION /AMBASSADOR BEADING	54
VOLVO LUGGAGE HINGE	55

<b>PART 4 - INDUSTRIAL &amp; GENERAL MISC</b>	
TABLE, OMEGA & DELTA SECTION, TARPULIN	56
A/C GRILL SECTION	57-58
MODULAR SHOWCASE SECTION	59
FLYSCREEN SECTION	60
SCAFOLD SECTION/TYRE SECTION	63-64





# PART I - BARS, RODS & TUBES

## MAJOR APPLICATIONS

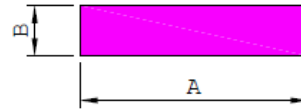

**PART I – BARS, RODS & TUBES****FLAT BAR**

SL. NO	SECTION NO	ITEMS (A X B)	WEIGHT KG/12Ft
1	1001 *	12.70 X 3.00	0.380
2	1002 *	12.50 X 6.35	0.800
3	1007 *	19.00 X 2.00	0.380
4	1008 *	19.05 X 2.95	0.560
5	1009	19.05 X 6.35	1.197
6	1010	19.05 X 9.50	1.800
7	1011	25.40 X 2.00	0.500
8	1013	25.40 X 3.00	0.770
9	1014	25.00 X 6.00	1.482
10	1015	25.40 X 9.52	2.386
11	1016	25.40 X 12.70	3.200
12	1062 *	25.00 X 16.00	4.000
13	1017 *	25.40 X 19.05	4.800
14	1018	30.00 X 2.95	0.900
15	1019	31.75 X 6.35	1.990
16	1020	31.75 X 9.52	3.000
17	1021	31.75 X 12.00	3.800
18	1022 *	32.00 X 15.88	5.000
19	1023 *	32.00 X 19.00	6.000
20	1025	38.10 X 3.00	1.171
21	1026	40.00 X 5.00	1.970
22	1027	38.10 X 6.35	2.390
23	1028	38.10 X 9.52	3.583
24	1073	40.00 X 6.00	2.371
25	1070	40.00 X 10.00	3.950
26	1029	38.10 X 12.70	4.780
27	1071	40.00 X 12.00	4.740
28	1063 *	38.00 X 25.00	9.500
29	1064 *	40.00 X 16.00	6.400
30	1024 *	40.00 X 20.00	7.900
31	1069	48.00 X 9.00	4.260
32	1030	50.00 X 2.85	1.300
33	1031	50.80 X 6.35	3.200
34	1066	50.80 X 9.52	4.770
35	1032	50.00 X 10.00	5.000

SL. NO	SECTION NO	ITEMS (A X B)	WEIGHT KG/12Ft
36	1033	50.00 X 12.00	6.000
37	1035 *	50.80 X 15.80	8.000
38	1036 *	50.80 X 19.05	9.600
39	1037 *	50.80 X 25.40	12.900
40	1038	63.50 X 6.35	4.000
41	1039	63.50 X 9.52	6.000
42	1067 *	60.00 X 10.00	5.900
43	1072	60.00 X 12.00	7.000
44	1040	63.50 X 12.70	8.000
45	1052 *	63.50 X 15.88	10.500
46	1041 *	63.50 X 19.05	12.000
47	1042 *	63.50 X 25.40	16.000
48	1043	76.20 X 6.35	4.779
49	1044	76.20 X 9.52	7.166
50	1045	76.20 X 12.70	9.563
51	1053 *	76.20 X 15.88	12.100
52	1046 *	80.00 X 10.00	8.000
53	1047	101.6 X 6.35	6.375
54	1048	100.0 X 10.00	9.882
55	1049	100.0 X 12.00	11.858
56	1050	101.1 X 12.70	12.751
57	1068	105.0 X 5.00	5.186
58	1051	120.0 X 10.00	11.858
59	1061	125 X 12.00	15.000
60	1054	127.0 X 6.35	7.968
61	1055	127.0 X 9.50	12.000
62	1056	127.0 X 12.70	15.939
63	1057	152.4 X 6.35	9.636
64	1058	150.0 X 10.00	14.823
65	1059	150.0 X 12.00	17.786
66	1065 *	140.0 X 10.00	14.000
67	1060	152.4 X 12.70	19.124

\* CONDITION APPLY



# PART I – BARS, RODS & TUBES

## ROUND ROD



SL.NO	SECTION NO	ITEMS (ØA)	WEIGHT PER 12Ft (3.66M)
1	1113	5.20	0.209
2	1101	6.00	0.278
3	1110	6.35	0.300
4	1102	8.00	0.498
5	1103	10.00	0.776
6	1104	12.00	1.116
7	1111	12.70	1.250
8	1106	15.88	1.939
9	1112	18.00	2.510
10	1107	19.05	2.818
11	1108	22.22	3.825
12	1109	25.40	4.656

## SQUARE TUBE

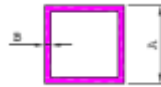

SL.NO	SECTION NO	ITEMS (A X B)	WEIGHT PER 12Ft (3.66M)
1	4001	17.00 x 0.52	0.340 - 0.380
2	4002	19.05 x 1.22	0.870 - 0.950
3	4003	25.40 x 1.04	1.001 - 1.100
4	4004	23.00 x 0.64	0.570 - 0.650
5	4005	20.00 x 2.10	1.500 - 1.650
6	4006	23.50 x 0.60	0.780 - 0.850
7	4007	25.40 x 1.63	1.550 - 1.700
8	4008	25.40 x 2.00	1.900 - 2.100
9	4013	36.00 x 0.61	0.850 - 1.000
10	4009	38.10 x 1.50	2.200 - 2.300
11	4012	50.00 x 1.00	2.000 - 2.100
12	4010	50.00 x 1.50	2.600 - 2.700
13	4011	50.00 x 1.80	3.200 - 3.400
14	4014	50.00 x 3.00	5.300 - 5.500
15	4015	32.00 x 0.60	0.740 - 0.760
16	4016	30.00 x 0.65	0.750 - 0.900
17	4017	23.00 x 0.50	0.400 - 0.480

**PART I – BARS, RODS & TUBES****SQUARE BAR**

SL.NO	SECTION NO	ITEMS (A)	WEIGHT PER 12Ft (3.66M)
1	1302	12.70	1.600
2	1303	15.88	2.500
3	1304	19.05	3.600
4	1305	25.40	6.400

**ROUND PIPE**

SL.NO	SECTION NO	ITEMS (ØA X B)	WEIGHT PER 12Ft (3.66M)
1	4112	11.90 x 1.75	0.500
2	4104	12.70 x 2.35	0.750
3	4105	15.88 x 2.24	0.950
4	4108	19.05 x 0.82	0.464
5	4110	19.05 x 1.63	0.900
6	4111	19.05 x 3.18	1.600
7	4114	22.22 x 1.63	1.100
8	4115	24.00 x 0.84	0.600
9	4117	25.40 x 1.22	0.900
10	4119	25.40 x 2.00	1.452
11	4120	25.40 x 3.20	2.200
11	4121	31.75 x 3.18	2.850
12	4122	28.20 x 1.60	1.300
13	4123	32.00 x 6.50	5.200
14	4124	45.00 x 2.00	2.700
15	4125	38.20 x 3.20	3.500
16	4126	42.00 x 2.00	2.700
17	4139	38.10 x 6.00	6.000
18	4127	50.80 X 2.00	3.000
19	4128	50.20 x 3.10	4.600
20	4131	50.80 x 3.50	5.200
21	4135	50.80 x 4.00	5.810
22	4129	50.00 x 5.00	7.000
23	4140	50.80 x 6.00	8.400
24	4130	52.00 x 7.00	9.900
25	4132	60.00 x 2.00	3.600
26	4133	63.50 x 3.18	5.955
27	4141	63.50 x 4.00	7.388
28	4142	63.50 x 6.25	11.200
29	4144	73.00 x 5.00	10.700
30	4145	76.20 x 6.30	13.800
31	4134	76.40 x 3.18	7.300
32	4136	86.35 x 3.15	8.200

# PART I – BARS, RODS & TUBES

## FLUTED PIPE

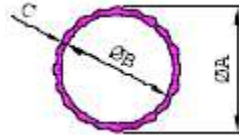

SL.NO	SECTION NO	ITEMS (A X C)	WEIGHT PER 12Ft (3.66M)
1	4201	19.05 x 0.65	0.400 – 0.450 Kgs
2	4202	24.80 x 0.49	0.560 – 0.600 Kgs
3	4203	25.40 x 1.49	1.350 – 1.500 Kgs
4	4204	25.00 x 1.40	0.800 – 0.900 Kgs
5	4207	24.80 x 0.60	0.580 – 0.620 Kgs
6	4206	25.40 x 0.79	0.850 – 0.900 Kgs

## SPL FLUTED PIPE

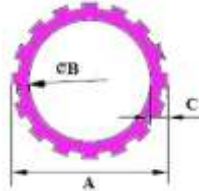

SL.NO	SECTION NO	ITEMS (A X B X C)	WEIGHT PER 12Ft (3.66M)
1	4200	19.05 x 14.05 x 2.50	1.100 – 1.200 Kgs
2	4205	25.80 x 20.00 x 2.90	1.600 – 1.700 Kgs

# PART I – BARS, RODS & TUBES

## RECTANGLE TUBE / RACEWAYS

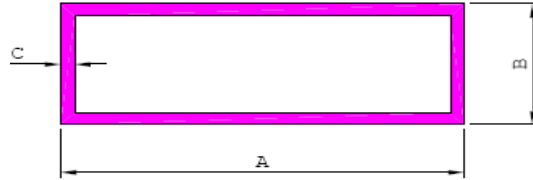

SL.NO	SECTION NO	ITEMS	WEIGHT PER 12Ft (3.66M)
1	2100	36.00 x 23.00 x 0.670	0.750 – 0.850 Kgs
2	2101	37.00 x 24.00 x 0.655	0.850 – 1.000 Kgs
3	2101	37.00 x 24.00 x 0.655	0.950 – 1.100 Kgs
4	2101	37.00 x 24.00 x 0.755	1.100 – 1.300 Kgs
5	2102	37.00 x 24.00 x 2.000	2.400 - 2.600 Kgs
6	2120	46.00 x 23.00 x 0.670	0.900 – 1.000 Kgs
7	2121	48.00 x 24.00 x 0.650	0.980 – 1.000 Kgs
8	2123	50.80 x 25.40 x 0.840	1.240 – 1.400 Kgs
9	2125	50.80 x 25.40 x 1.130	1.650 – 1.800 Kgs
10	2126	50.80 x 25.40 x 1.500	1.950 – 2.100 Kgs
11	2126	50.80 x 25.40 x 1.650	2.400 – 2.500 Kgs
12	2128	50.80 x 25.40 x 2.000	2.900 – 3.200 Kgs
13	2144	63.50 x 38.10 x 1.200	2.100 – 2.300 Kgs
14	2146	63.00 x 38.10 x 1.470	2.851 – 3.100 Kgs
15	2148	63.50 x 38.10 x 2.000	3.857 – 4.100 Kgs
16	2155	76.20 x 25.40 x 1.500	2.920 – 3.120 Kgs
17	2156	76.20 x 25.40 x 2.000	3.800 - 4.300 Kgs
18	2152	80.00 x 50.00 x 2.000	5.000 – 5.200 Kgs
19	2160	101.6 x 44.75 x 1.450	4.000 – 4.300 Kgs
20	2166	101.6 x 44.75 x 1.770	5.000 – 5.300 Kgs
21	2170	101.6 x 44.75 x 3.180	8.800 – 9.200 Kgs

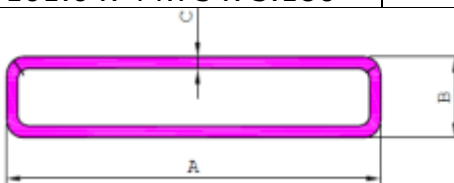

SL.NO	SECTION NO	ITEMS	WEIGHT PER 12Ft (3.66M)
1	3369	73.00 x 25.00 x 1.70	3.150 Kgs



SL.NO	SECTION NO	ITEMS (A X B)	WEIGHT PER 12Ft (3.66M)
1	2138	75.00 x 25.00 x 1.50	3.100 – 3.300 Kgs



# PART II - STRUCTURAL & ARCHITECTURAL

## MAJOR APPLICATIONS

**Casement Windows**



**Sliding Windows**



**Doors**



**Shop Front**



**Louvers**



**Exhibition Sections**



**Glazing Profiles**



## PART II – STRUCTURAL & ARCHITECTURAL EQUAL ANGLE

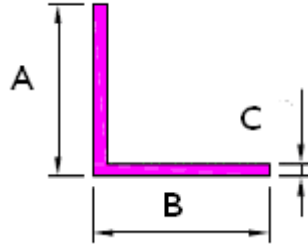

SL.NO	SECTION NO	ITEMS (A X B X C)	WEIGHT PER 12Ft (3.66M)
1	3000	19.05 X 19.05 X 1.50	0.550 – 0.600
2	3001	19.05 X 19.05 X 2.20	0.802 – 0.900
3	3002	19.05 X 19.05 X 3.00	1.000 – 1.100
4	3003	25.40 X 25.40 X 0.56	0.350 – 0.450
5	3004	25.00 X 25.00 X 1.00	0.497 – 0.600
6	3005	25.00 X 25.00 X 1.50	0.730 – 0.800
7	3006	25.00 X 25.00 X 2.00	0.999 – 1.100
8	3007	25.00 X 25.00 X 3.00	1.479 – 1.600
9	3016	30.00 X 30.00 X 2.50	1.450 – 1.600
10	3008	31.75 X 31.75 X 2.80	1.780 – 1.900
11	3018	38.10 X 38.10 X 1.60	1.200 – 1.400
12	3009	38.10 X 38.10 X 2.50	1.819 – 1.950
13	3010	38.00 X 38.00 X 3.00	2.200 – 2.300
14	3011	38.10 X 38.10 X 4.70	3.370 – 3.500
15	3012	38.10 X 38.10 X 6.00	4.381 – 4.500
16	3013	50.00 X 50.00 X 3.00	2.855 – 3.000
17	3019	50.00 X 50.00 X 4.00	3.800 – 4.500
18	3014	50.00 X 50.00 X 4.70	4.568 – 4.700
19	3015	50.00 X 50.00 X 6.00	5.856 – 6.000
20	3017*	76.20 X 76.20 X 6.20	9.000 – 9.200

## UNEQUAL ANGLE

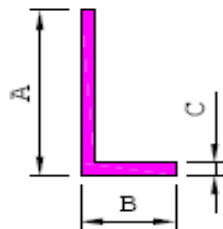

SL.NO	SECTION NO	ITEMS (A X B X C)	WEIGHT PER 12Ft (3.66M)
1	3100	38.1 X 25.4 X 1.89	1.150 – 1.300
2	3102	38.1 X 25.4 X 2.90	1.700 – 1.900
3	3105 *	50.0 X 25.0 X 2.50	1.800 – 2.000



## PART II – STRUCTURAL & ARCHITECTURAL FLUTED ANGLE

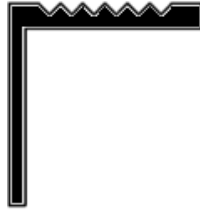

SL.NO	SECTION NO	ITEMS	WEIGHT PER 12Ft (3.66M)
1	3160	19.05 X 19.85 X 1.10	0.670 – 0.800 Kgs
2.	3161	25.40 X 25.40 X 1.50	0.850 – 0.950 Kgs
3.	3162	31.75 X 31.75 X 1.50	1.200 - 1.400 Kgs

## CLEAT ANGLE

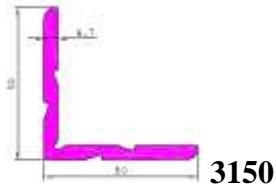

3150

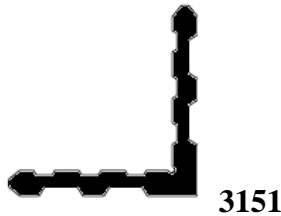

3151



3152



3153

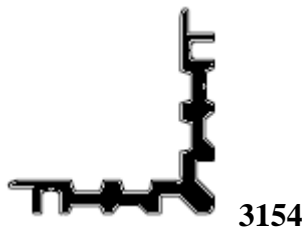

3154

SL.NO	SECTION NO	ITEMS (A X B XC )	WEIGHT PER 12Ft (3.66M)
1	3150	50 X 50 X 4.70	3.700 – 4.000 Kgs
2	3151	50 X 50 X 6.00	4.600 – 4.700 Kgs
3	3152	50 X 50 X 7.50	5.700 – 5.900 Kgs
4	3153	62 X 62 X 4.40	3.500 – 3.700 Kgs
5	3154	70.75 X 70.75 X 3.65	8.700 – 8.900 Kgs

# PART II – STRUCTURAL & ARCHITECTURAL CHANNELS CHANNELS – SQUARE FILLET

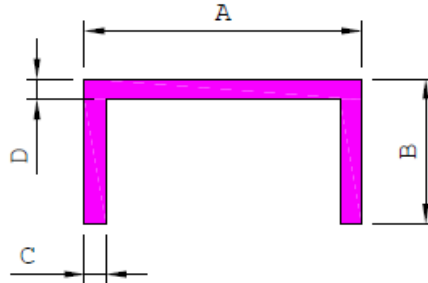

SL.NO	SECTION NO	ITEMS	WEIGHT PER 12Ft (3.66M)
1	3350	101.60 x 41.80 x 6.68	13.700 Kgs
2	3353	101.60 x 40.00 x 3.00	5.200 Kgs
3	3354	38.00 x 30.00 x 2.00	1.850 Kgs

## CHANNELS – ROUND FILLET TOES

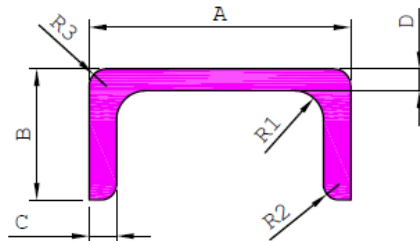

SL.NO	SECTION NO	ITEMS (A x B X C)	WEIGHT PER 12Ft (3.66M)
1	3351	76.20 x 38.10 x 7.94	10.000 Kgs
2	3352	101.60 x 50.80 x 6.00	11.600 Kgs

## SINGLE CHANNEL



SL.NO	SECTION NO	ITEMS	WEIGHT PER 12Ft (3.66M)
1	8001	9.00 x 9.00 x 0.88	0.220 - 0.250 Kgs
2	8007	12.70 x 12.70 x 0.85	0.300 - 0.350 Kgs
3	8011	24.00 x 11.00 x 1.10	0.450 - 0.500 Kgs
4	8012	25.40 x 12.70 x 2.00	0.930 - 1.000 Kgs
5	8013	25.40 x 12.70 x 1.22	0.600 - 0.650 Kgs
6	8014	25.00 x 25.00 x 2.00	1.400 - 1.500 Kgs

# PART II – STRUCTURAL & ARCHITECTURAL DOUBLE CHANNEL



SL.NO	SECTION NO	ITEMS	WEIGHT PER 12Ft (3.66M)
1	4502	22.00 x 11.00 x 0.72	0.390 - 0.400
2	4503	22.45 x 12.80 x 0.67	0.390 - 0.420
3	4505	22.00 x 11.00 x 0.90	0.475 - 0.500
4	4509	22.00 x 11.00 x 1.00	0.520 - 0.600
5	4511	22.23 x 12.70 x 1.05	0.600 - 0.800
6	4513	28.00 x 15.50 x 0.80	0.550 - 0.600
7	4514	28.00 x 15.50 x 1.10	0.780 - 0.900

## C CHANNEL

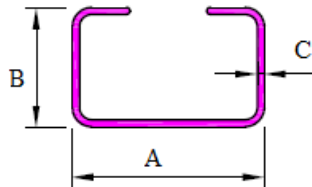

SL.NO	SECTION NO	ITEMS	WEIGHT PER 12Ft (3.66M)
1	4530	22.50 x 14 x 0.70	0.350- 0.400

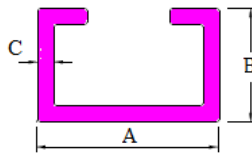

SL.NO	SECTION NO	ITEMS	WEIGHT PER 12Ft (3.66M)
1	4531	22.50 x 14 x 2.00	1.080- 1.200

## TEE SECTION

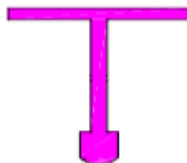

SL.NO	SECTION NO	ITEMS	WEIGHT PER 12Ft (3.66M)
1	8200	23.00 x 23.00 x 0.569	0.280 - 0.350
2	8201	24.50 x 25.00 x 0.065	0.350 - 0.400
3	8203	25.00 x 24.50 x 0.950	0.500 - 0.550
4	8204	25.00 x 25.00 x 1.350	0.720 - 0.800
5	8205	32.00 x 32.00 x 1.450	0.900 - 1.000
6	8206	38.10 x 38.10 x 1.400	1.190 - 1.300

## PART II – STRUCTURAL & ARCHITECTURAL HALF ROUND TEE SECTION

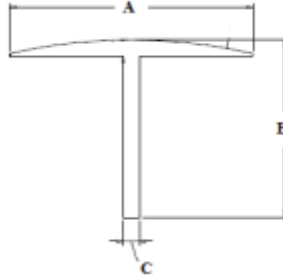

SL.NO	SECTION NO	ITEMS	WEIGHT PER 12Ft (3.66M)
1	3170	75.00 x 54.60 x 5.000	5.200-5.400 Kgs

### GRILL

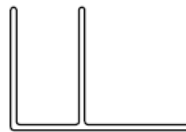

SL.NO	SECTION NO	ITEMS	WEIGHT PER 12Ft (3.66M)
1	4401	21.0 x 16.00 x 0.85 ( 8 mm)	0.350 – 0.400 Kgs
2	4402	21.0 x 16.00 x 0.70 (10 mm )	0.350 – 0.400 Kgs

### GEAR SECTION



SL.NO	SECTION NO	ITEMS	WEIGHT PER 12Ft(3.66M)
1	8250	40.00 x40.00 x 1.90mm	2.100 – 2.250 Kgs

### GEAR SECTION – SPL

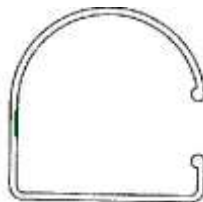

SL.NO	SECTION NO	ITEMS	WEIGHT PER 12Ft(3.66M)
1	8251	40.00 x 40.00 x1.45mm	1.850 – 2.000 Kgs

## PART II – STRUCTURAL & ARCHITECTURAL LADDER



SL.NO	SECTION NO	ITEMS (A X B X C)	WEIGHT PER 20feet
1	4307	59.70 x 28.80 x 1.35 MM	2.500 – 2.700 Kgs
2	4300	66.60 x 31.75 x 1.75 MM	3.500 - 3.700 Kgs
3	4301	66.60 x 31.75 x 2.00 MM	3.800 – 4.200 Kgs
4	4302	66.60 x 31.75 x 2.50 MM	4.984 – 5.300 Kgs
5	4303	66.60 x 31.75 x 3.00 MM	6.283 – 6.500 Kgs

### MULLION STEPEDGE

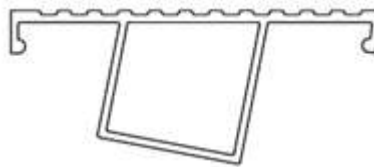

SL.NO	SECTION NO	ITEMS (A X B)	WEIGHT PER 12Ft (3.66M)
1	4308	65.2 x 1.35MM	2.200 – 2.400 Kgs
2	4310	55.8 x 1.40MM	1.800 – 2.000 Kgs

### MULLION STEPEDGE

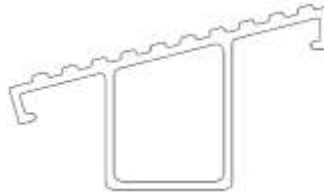

SL.NO	SECTION NO	ITEMS (A X B)	WEIGHT PER 12Ft (3.66M)
1	4311	63.00 x 1.65MM	2.900 – 3.100 Kgs

### FLUTTED LADDER SMALL



SL.NO	SECTION NO	ITEMS (A X B X C)	WEIGHT PER 12Ft (3.66M)
1	4315	48.92 x 24.47 x 1.20 MM	1.170 – 1.400 Kgs
2	4316	66.60 x 31.75 x 1.50 MM	2.000 – 2.200 Kgs

## PART II – STRUCTURAL & ARCHITECTURAL RECTANGULAR LADDER STEP

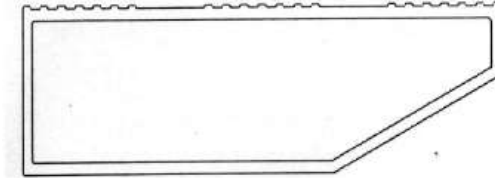

SL.NO	SECTION NO	ITEMS (A X B X C)	WEIGHT PER 12Ft (3.66M)
1	4318	100 x 28.00 x 2.00 MM	4.500 – 4.800 Kgs

## FLUTED RECTANGLE TUBE

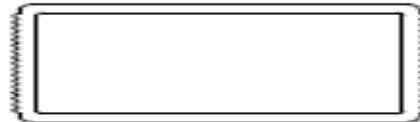

SL.NO	SECTION NO	ITEMS (A X B)	WEIGHT PER 12Ft (3.66M)
1	2135	33 x 20 x 1.30MM	1.400 – 1.600 Kgs
2	2136	50 x 20 x 1.30MM	1.800 – 2.000 Kgs

## LADDER STEP



SL.NO	SECTION NO	ITEMS	WEIGHT PER 12Ft (3.66M)
1	2139	76.50 x 32.30 x 1.400MM	2.200 – 2.500 Kgs

## LADDER SPECIAL STEP



SL.NO	SECTION NO	ITEMS	WEIGHT PER 12Ft (3.66M)
1	4313	79.70 x 33.70 x 1.200MM	2.100 – 2.300 Kgs





## PART II – STRUCTURAL & ARCHITECTURAL LADDER RT SECTION

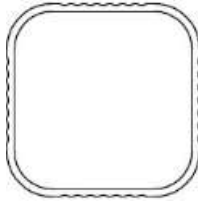

SL.NO	SECTION NO	ITEMS (A X B X C)	WEIGHT PER 12Ft (3.66M)
1	4030	30.00 X 30.00 X 1.200MM	1.200 – 1.300 Kgs

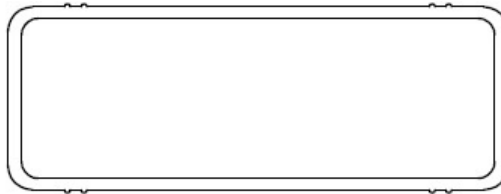

SL.NO	SECTION NO	ITEMS (A X B X C)	WEIGHT PER 12Ft (3.66M)
1	4031	60.40 x 22.10 x 1.700MM	2.300 – 2.400 Kgs

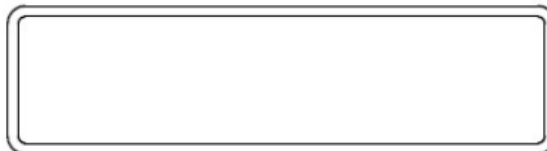

SL.NO	SECTION NO	ITEMS (A X B X C)	WEIGHT PER 12Ft (3.66M)
1	4032	63.00 x 17.00 x 1.200MM	1.800 – 2.00 Kgs

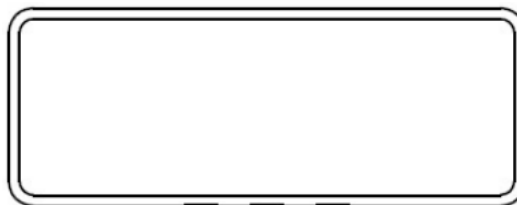

SL.NO	SECTION NO	ITEMS (A X B X C)	WEIGHT PER 12Ft (3.66M)
1	4033	62.60 x 24.00 x 1.300MM	2.000 – 2.200 Kgs

## PART II – STRUCTURAL & ARCHITECTURAL CLIP



SL.NO	SECTION NO	ITEMS	WEIGHT PER 12Ft (3.66M)
1	2002	19.00 x 17.30 x 0.400	0.240 – 0.260 Kgs
2	2003	19.00 x 17.30 x 0.500	0.280 – 0.320 Kgs
3	2008	19.00 x 17.00 x 0.900	0.430 – 0.500 Kgs
4	2010	17.15 x 17.27 x 1.500	0.630 – 0.700 Kgs

## CLIP - SPECIAL GLAZING

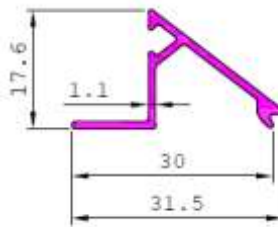

SL.NO	SECTION NO	ITEMS	WEIGHT PER 12Ft (3.66M)
1	6700	31.50 x 17.60 x 1.10	0.600 – 0.640 Kgs

## CLIP-ADAPTOR – OPENABLE WINDOW



SL.NO	SECTION NO	ITEMS	WEIGHT PER 12Ft (3.66M)
1	2050	30.20 x 16.50 x 1.50	0.996- 1.000 Kgs



## PART II – STRUCTURAL & ARCHITECTURAL PARTITIONS - SINGLE GROOVE



SL.NO	SECTION NO	ITEMS	WEIGHT PER 12Ft (3.66M)
1	2203	50.8 x 25.40 x 0.740	1.300 – 1.500 Kgs
2	2203	50.8 x 25.40 x 0.740	1.000 – 1.150 Kgs
3	2204	50.8 x 25.40 x 0.900	1.520 – 1.700 Kgs
4	2206	50.8 x 25.40 x 1.520	2.000 – 2.200 Kgs
5	2221	63.5 x 38.10 x 0.740	1.600 – 1.800 Kgs
6	2222	63.5 x 38.10 x 0.740	1.600 – 1.800 Kgs
7	2224	63.5 x 38.10 x 0.910	2.000 – 2.200 Kgs
8	2224	63.5 x 38.10 x 0.910	2.300 – 2.500 Kgs
9	2228	63.5 x 38.10 x 1.163	2.800 – 3.000 Kgs
10	2230	63.1 x 38.10 x 1.800	3.900 – 4.100 Kgs
11	2264	101.6 x 44.45 x 1.550	4.600 – 4.800 Kgs
12	2267	101.6 x 44.45 x 2.000	5.900 – 6.100 Kgs
13	2269	101.5 x 44.45 x 2.500	7.300 – 7.500 Kgs

## DOUBLE GROOVE

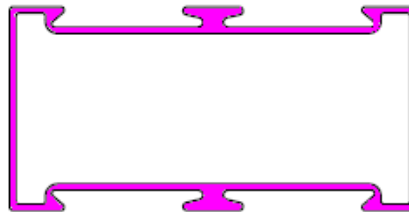

SL.NO	SECTION NO	ITEMS	WEIGHT PER 12Ft (3.66M)
1	2302	50.8 x 25.40 x 0.615	1.291 – 1.400 Kgs
2	2302	50.8 x 25.40 x 0.615	1.000 – 1.150 Kgs
3	2303	50.8 x 25.40 x 0.900	1.500 – 1.700 kGS
4	2305	50.8 x 25.40 x 1.520	2.050 – 2.200 Kgs
5	2320	63.5 x 38.10 x 0.626	1.610 – 1.800 Kgs
6	2321	63.5 x 38.10 x 0.626	1.610 – 1.800 Kgs
7	2323	63.5 x 38.10 x 0.917	2.000 – 2.200 Kgs
7	2323	63.5 x 38.10 x 0.917	2.300 – 2.500 Kgs
8	2326	63.1 x 38.10 x 1.200	2.700 – 2.900 Kgs
9	2327	63.1 x 38.10 x 1.800	3.900 – 4.100 Kgs
10	2364	101.6 x 44.45 x 1.551	4.600 – 4.800 Kgs
11	2370	101.6 x 44.45 x 1.950	5.900 – 6.200 Kgs
12	2366	101.6 x 44.45 x 2.380	7.000- 7.150 Kgs

## PART II – STRUCTURAL & ARCHITECTURAL DOOR TOP

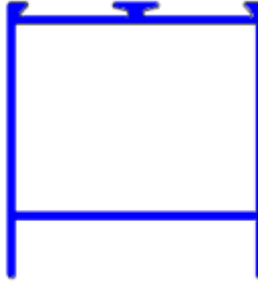

SL.NO	SECTION NO	ITEMS	WEIGHT PER 12Ft (3.66M)
1	2401	47.62 x 44.45 x 1.123	2.200 – 2.450 Kgs
2	2404	47.62 x 44.45 x 1.379	2.600 – 2.800 Kgs
3	2406	50.00 x 44.50 x 2.500	4.800 – 5.000 Kgs

## DOOR VERTICAL

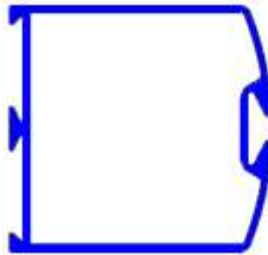

SL.NO	SECTION NO	ITEMS	WEIGHT PER 12Ft (3.66M)
1	2419	47.62 x 44.45 x 0.750	1.800 – 1.900 Kgs
2	2420	47.62 x 44.45 x 1.140	2.450 – 2.600 Kgs
3	2422	47.62 x 44.45 x 1.620	3.230 – 3.500 Kgs
4	2423	47.62 x 44.50 x 1.860	3.600 – 3.800 Kgs
5	2425	50.00 x 44.50 x 2.500	4.600 – 4.800 Kgs
6	2426	85.00 x 44.45 x 2.900	7.400 – 7.600 Kgs
7	2427	85.00 x 44.45 x 1.560	4.200 – 4.600 Kgs

## DOOR HANDLE – BUTTERFLY Type

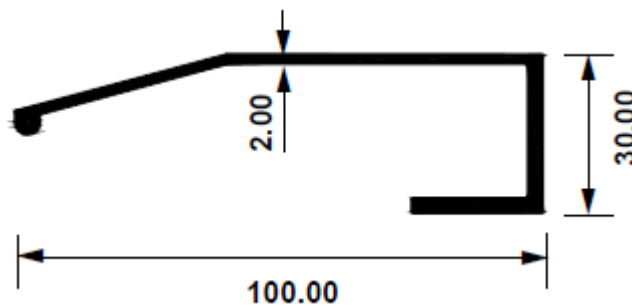

SL.NO	SECTION NO	ITEMS	WEIGHT PER 12Ft (3.66M)
1	8030 *	100.00 x 30.00 x 2.00	3.600 – 3.800 Kgs

## PART II – STRUCTURAL & ARCHITECTURAL DOOR MIDDLE SINGLE GROOVE



SL.NO	SECTION NO	ITEMS	WEIGHT PER 12Ft (3.66M)
1	2442	47.62 x 44.45 x 1.425	2.200 – 2.400 Kgs

## DOOR MIDDLE DOUBLE GROOVE

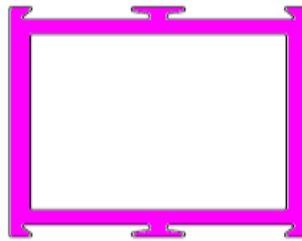

SL.NO	SECTION NO	ITEMS	WEIGHT PER 12Ft (3.66M)
1	2461	47.62 x 44.45 x 1.500	2.100 – 2.300 Kgs
2	2462	50.00 x 45.00 x 2.500	4.700 – 4.900 Kgs

## DOOR BOTTOM



SL.NO	SECTION NO	ITEMS	WEIGHT PER 12Ft (3.66M)
1	2480	95.25 x 44.45 x 1.000	2.600 – 2.800 Kgs
2	2481	95.25 x 44.45 x 1.150	3.300 – 3.500 Kgs
3	2486	95.25 x 44.45 x 1.720	4.800 – 5.000 Kgs
4	2488	100.00 x 44.50 x 2.500	7.200 – 7.500 Kgs

## PART II – STRUCTURAL & ARCHITECTURAL DOOR BOTTOM - FISH

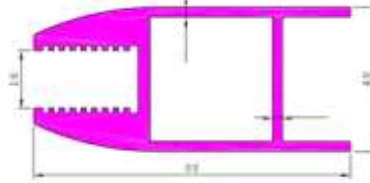

SL.NO	SECTION NO	ITEMS	WEIGHT PER 12Ft (3.66M)
1	2469	88 X 40 X 1.81	4.600 – 5.000 Kgs
2	2470	88 x 40 x 2.50	7.500 – 7.700 Kgs

## GLAZING PLATE



SL.NO	SECTION NO	ITEMS	WEIGHT PER 12Ft (3.66M)
1	2490	44.45 x 3.3 x 0.763	0.600 – 0.650 Kgs

## DOOR FRAME

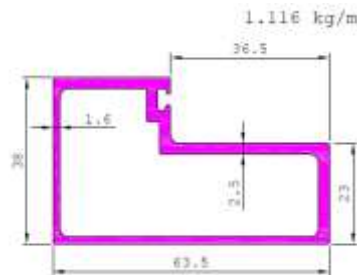
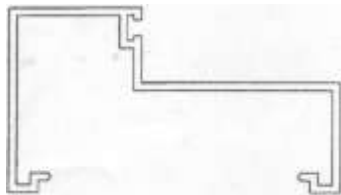

SL.NO	SECTION NO	ITEMS	WEIGHT PER 12Ft (3.66M)
1	2450	80.00 x 45.50 x 1.80	3.500 – 3.800 Kgs
2	2455	63.50 x 38.00 x 2.40	4.500 – 4.700 Kgs

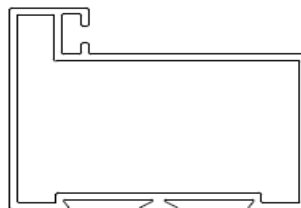

SL.NO	SECTION NO	ITEMS	WEIGHT PER 12Ft (3.66M)
1	2456	64 x 50.10 x 2.00	4.700 – 4.900 Kgs



## PART II – STRUCTURAL & ARCHITECTURAL LOUVER



2452

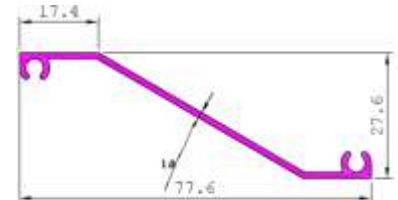

2453

SL.NO	SECTION NO	ITEMS	WEIGHT PER 12Ft (3.66M)
1	2452	103.20 x 50.80 x 1.70	2.400-2.600 Kgs
2	2453	77.6 x 27.60 x 1.00	1.100 – 1.400 Kgs

## WINDOW FRAME

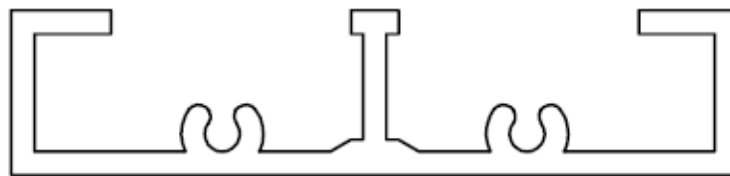

SL.NO	SECTION NO	ITEMS	WEIGHT PER 12Ft (3.66M)
1	2451	62 x 14 x 1.50	2.650 – 2.800 Kgs

## SPL SHUTTER

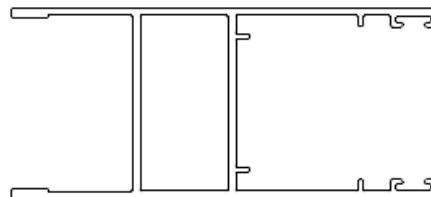

SL.NO	SECTION NO	ITEMS	WEIGHT PER 12Ft (3.66M)
1	6705	90 X 40 X 1.50	4.400 – 4.600 Kgs

# PART II – STRUCTURAL & ARCHITECTURAL

## 12MM WINDOW SERIES

### 12MM RUNNER

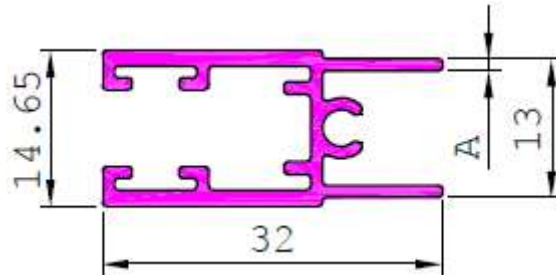

SL.NO	SECTION NO	ITEMS	WEIGHT PER 12Ft (3.66M)
1	2500	32 x 14.65 x 0.80	0.750 – 0.850 Kgs

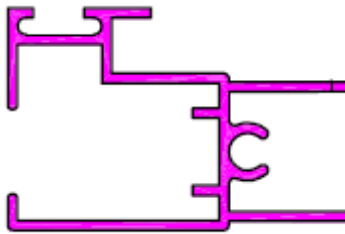

SL.NO	SECTION NO	ITEMS	WEIGHT PER 12Ft (3.66M)
1	2505	32 x 20.50 x 0.82	0.750 – 0.850 Kgs

### 12MM TWO TRACK

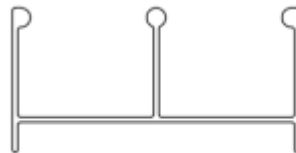

SL.NO	SECTION NO	ITEMS	WEIGHT PER 12Ft (3.66M)
1	2507	45.20 x 22.50 x 1.5	1.100 – 1.200 Kgs

### 1" BULB C TRACK

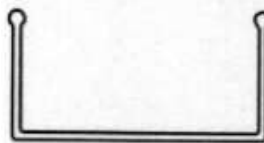

SL.NO	SECTION NO	ITEMS	WEIGHT PER 12Ft (3.66M)
1	2508	24.60 x 12.20 x 0.73	0.350 – 0.450 Kgs

## PART II – STRUCTURAL & ARCHITECTURAL

### 15MM WINDOW SERIES

### 15MM RUNNER

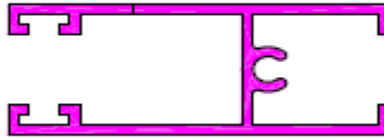

SL.NO	SECTION NO	ITEMS	WEIGHT PER 12Ft (3.66M)
1	2520	37.5 x 15 x 0.96	1.105 – 1.250 Kgs
2	2522	37.5 x 15 x 1.17	1.320 – 1.500 Kgs
3	2526	37.5 x 15 x 1.55	1.639 – 1.750 Kgs

### 15MM INTER LOCK

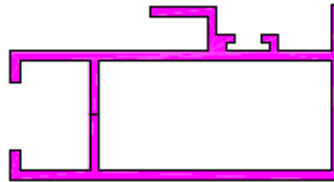

SL.NO	SECTION NO	ITEMS	WEIGHT PER 12Ft (3.66M)
1	2510	37.5 x 15 x 0.775	1.005 – 1.200 Kgs
2	2513	37.5 x 15 x 1.050	1.350 – 1.500 Kgs
3	2516	37.5 x 15 x 1.170	1.500 – 1.750 Kgs

### 15MM TWO TRACK SLIDING WINDOW

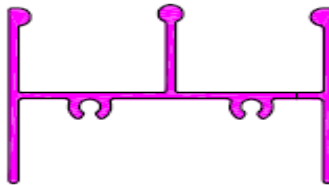

SL.NO	SECTION NO	ITEMS	WEIGHT PER 12Ft (3.66M)
1	2530	45.2 x 35 x 0.85	1.405 – 1.600 Kgs
2	2531	45.2 x 35 x 0.97	1.512 – 1.700 Kgs
3	2535	45.2 x 35 x 1.36	2.000 – 2.200 Kgs

# PART II – STRUCTURAL & ARCHITECTURAL

## 18MM WINDOW SERIES

### 18MM – SHUTTER SIDE

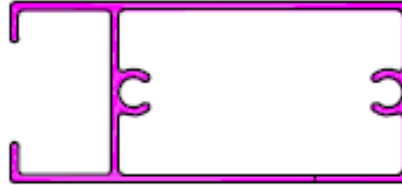

SL.NO	SECTION NO	ITEMS	WEIGHT PER 12Ft (3.66M)
1	2600	40.0 x 18.0 x 0.71	0.750 – 0.850 Kgs
2	2603	40.0 x 18.0 x 0.99	1.300 - 1.500 Kgs
3	2604	50.8 x 18.0 x 1.10	1.600 – 1.800 Kgs
4	2605	40.0 x 18.0 x 1.40	1.800 – 2.000 Kgs

### 18MM LOCK

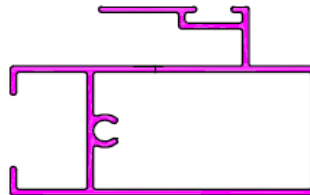

SL.NO	SECTION NO	ITEMS	WEIGHT PER 12Ft (3.66M)
1	2611	40 x 18.0 x 0.80	1.100 - 1.300 Kgs
2	2613	40 x 18.0 x 0.89	1.420 – 1.600 Kgs
3	2614	50 x 26.7 x 1.10	1.900 - 2.000 Kgs
4	2615	40 x 18.0 x 1.16	1.900 – 2.000 Kgs

### 18MM RUNNER

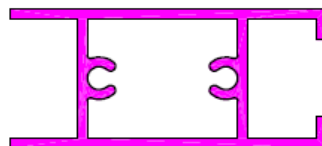

SL.NO	SECTION NO	ITEMS	WEIGHT PER 12Ft (3.66M)
1	2622	40.00 x 18.00 x 0.91	1.211 – 1.350 Kgs
2	2624	52.00 x 18.00 x 1.13	1.780 – 1.800 Kgs
3	2625	40.00 x 18.00 x 1.40	1.800 - 2.000 Kgs

## PART II – STRUCTURAL & ARCHITECTURAL 20MM WINDOW SERIES 20MM RUNNER

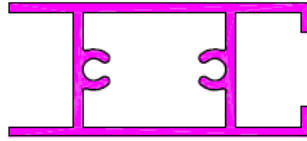

SL.NO	SECTION NO	ITEMS	WEIGHT PER 12Ft (3.66M)
1	2720	41 x 20 x 1.08	1.280 – 1.400 Kgs

## 20MM RUNNER / SHUTTER TOP & BOTTOM

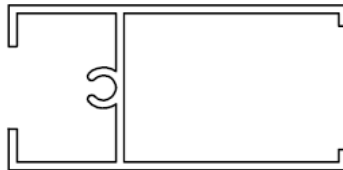

SL.NO	SECTION NO	ITEMS	WEIGHT PER 12Ft (3.66M)
1	2723	41 x 20 x 0.98	1.150 – 1.300 Kgs
2	2725	41 x 20 x 1.50	1.700 – 1.900 Kgs

## 20MM SHUTTER SECTION



SL.NO	SECTION NO	ITEMS	WEIGHT PER 12Ft (3.66M)
1	2700	39 x 20 x 0.80	0.750 – 0.850 Kgs
2	2701	39 x 20 x 1.50	1.776 – 1.900 Kgs
3	2704	46 x 20 x 0.70	0.850 – 0.950 Kgs

## 20MM SHUTTER INTERLOCK

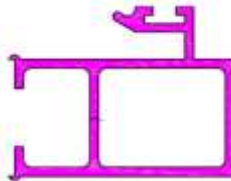

SL.NO	SECTION NO	ITEMS	WEIGHT PER 12Ft (3.66M)
1	2713	39 x 20 x 1.0	1.500 - 1.800 Kgs
2	2713	39 x 20 x 1.5	1.800 – 2.000 Kgs

## PART II – STRUCTURAL & ARCHITECTURAL

### 20MM TWO TRACK SIDE & TOP

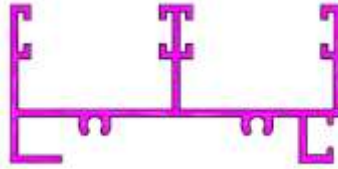

SL.NO	SECTION NO	ITEMS	WEIGHT PER 12Ft (3.66M)
1	2740	62 x 29.5 x 1.000	2.000 – 2.200 Kgs
2	2743	62 x 29.5 x 1.300	2.536 – 2.750 Kgs

### 20MM TWO TRACK BOTTOM

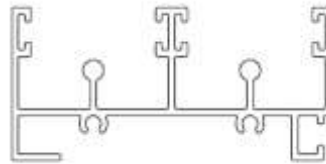

SL.NO	SECTION NO	ITEMS	WEIGHT PER 12Ft (3.66M)
1	2731	62 x 29.5 x 1.1	2.117 – 2.300 Kgs
2	2732	62 x 29.5 x 1.2	2.536 – 2.750 Kgs
3	2733	62 x 29.5 x 1.3	2.900 – 3.100 Kgs
4	2734	61.98 X 29.70 X 1.6	3.200 – 3.300 Kgs

### 20MM THREE TRACK BOTTOM

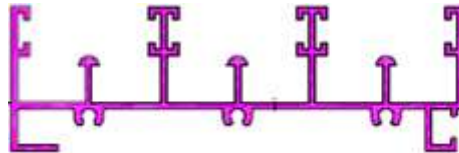

SL.NO	SECTION NO	ITEM	WEIGHT PER 12Ft (3.66M)
1	2752	92 x 29.50 x 1.05	3.250 – 3.500 Kgs
2	2754	92 x 29.50 x 1.50	4.500 – 4.700 Kgs



## PART II – STRUCTURAL & ARCHITECTURAL 20MM THREE TRACK SIDE-TOP

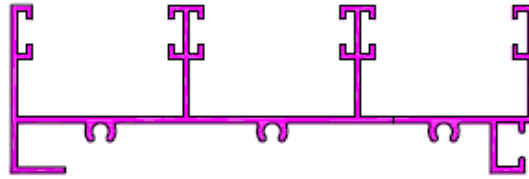

SL.NO	SECTION NO	ITEMS	WEIGHT PER 12Ft (3.66M)
1	2761	92.00 x 29.50 x 1.200	3.250 – 3.500 Kgs
2	2764	92.36 x 29.70 x 1.500	3.900 – 4.100 Kgs

## 20MM FOUR TRACK BOTTOM

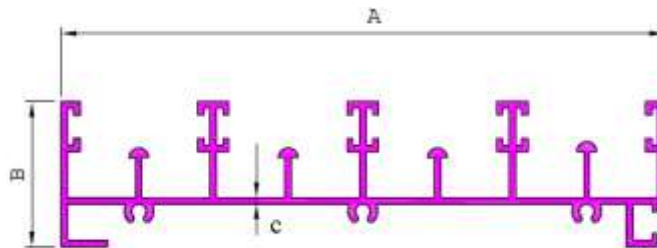

SL.NO	SECTION NO	ITEMS	WEIGHT PER 12Ft (3.66M)
1	2782	123 x 29.5 x 1.30	5.110 Kgs

## 20MM FOUR TRACK SIDE & TOP

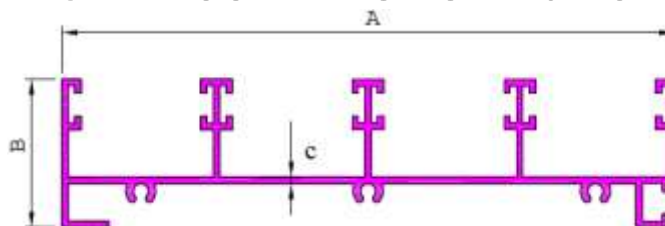

SL.NO	SECTION NO	ITEMS	WEIGHT PER 12Ft (3.66M)
1	2780	123 x 29.50 x 1.30	4.480Kgs



# **PART II – STRUCTURAL & ARCHITECTURAL**

## **20MM THREE TRACK GUTTER BOTTOM**

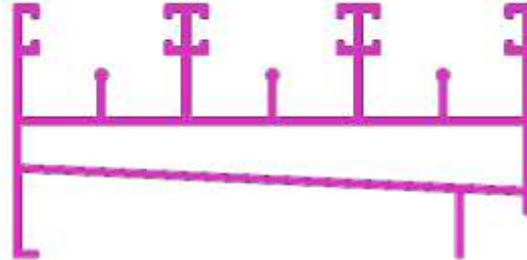

<b>SL.NO</b>	<b>SECTION NO</b>	<b>ITEMS</b>	<b>WEIGHT PER 12Ft (3.66M)</b>
1	2736	92 x 45.00 x 1.500	5.900 – 6.100 Kgs

# PART II – STRUCTURAL & ARCHITECTURAL

## 25MM WINDOW SERIES

### SLIDING DOOR - 25MM TWO TRACK SIDE & TOP

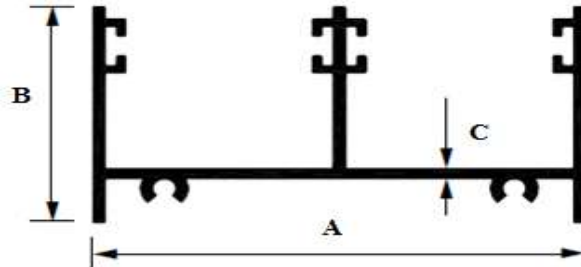

SL.NO	SECTION NO	ITEMS (A x B x C)	WEIGHT PER 12Ft (3.66M)
1	2670	82.80 X 44 X 2.00	4.950 – 5.500 KGS

### 25MM THREE TRACK SIDE & TOP

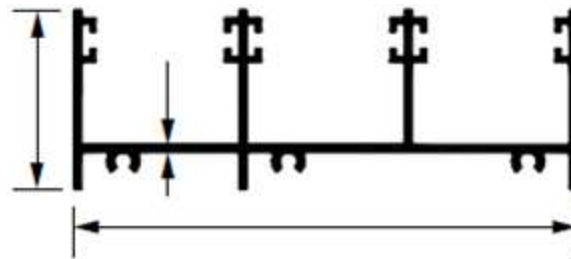

SL.NO	SECTION NO	ITEMS	WEIGHT PER 12Ft (3.66M)
1	2671	123.20 X 44 X 2.00	7.200 – 7.900 KGS

### 25MM THREE TRACK BOTTOM

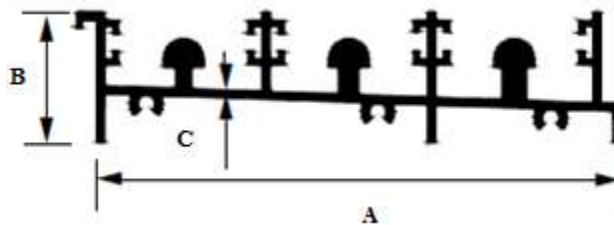

SL.NO	SECTION NO	ITEMS (A x B x C)	WEIGHT PER 12Ft (3.66M)
1	2672	128 X 32 X 2.00	9.000 – 9.900 KGS

## PART II – STRUCTURAL & ARCHITECTURAL

### 25MM SHUTTER VERTICAL

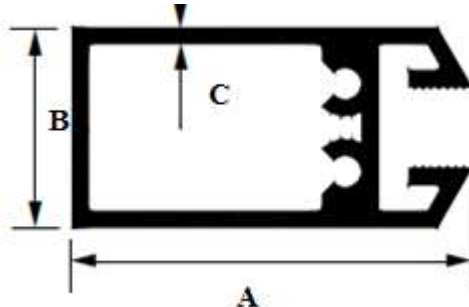

SL.NO	SECTION NO	ITEMS(A x B x C)	WEIGHT PER 12Ft (3.66M)
1	2673	50.8 X 25.4 X 2.00	3.700 – 4.200 KGS

### 25MM SHUTTER INTERLOCK

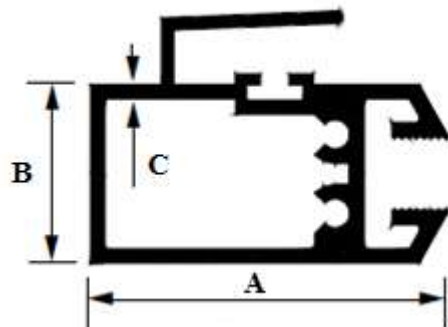

SL.NO	SECTION NO	ITEMS (A x B x C)	WEIGHT PER 12Ft (3.66M)
1	2674	50.8 X 25.4 X 2.00	4.400 – 4.900 KGS

### 25MM TWO TRACK BOTTOM

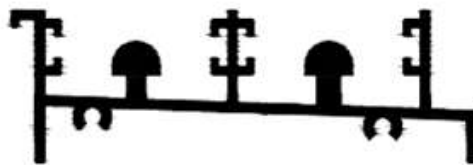

SL.NO	SECTION NO	ITEMS	WEIGHT PER 12Ft (3.66M)
1	2675	92.6 X 32 X 2.00	6.200 – 6.800 KGS



# PART II – STRUCTURAL & ARCHITECTURAL 25MM SHUTTER TOP & BOTTOM



SL.NO	SECTION NO	ITEMS	WEIGHT PER 12Ft (3.66M)
1	2676	69 X 25.4 X 2.00	4.100 – 4.500 KGS

# 25MM SLIDING WINDOW D- SERIES 25MM SHUTTER

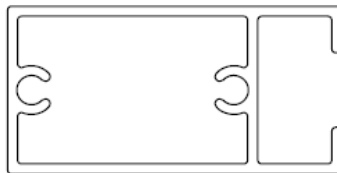

SL.NO	SECTION NO	ITEMS	WEIGHT PER 12Ft (3.66M)
1	2783	50 X 25 X1.50	2.600- 3.000 Kgs

# 25MM RUNNER

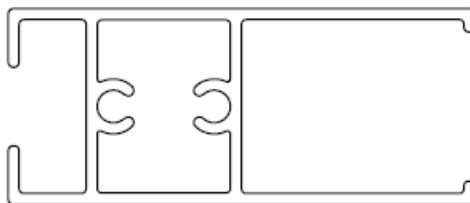

SL.NO	SECTION NO	ITEMS	WEIGHT PER 12Ft (3.66M)
1	2784	60 X 25.05 X 1.44	2.800 – 3.000 Kgs

# PART II – STRUCTURAL & ARCHITECTURAL

## 25MM SLIDING WINDOW D-SERIES

### 25MM LOCK

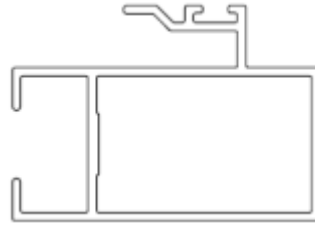

SL.NO	SECTION NO	ITEMS	WEIGHT PER 12Ft (3.66M)
1	2785	50 X 25.05 X 1.29	2.600 – 3.00Kgs

### 25MM - 3 TRACK SIDE & TOP

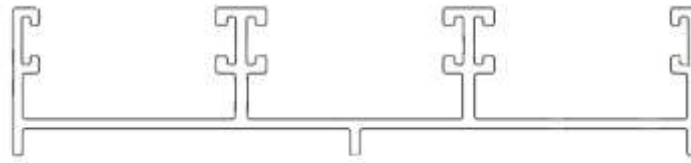

SL.NO	SECTION NO	ITEMS	WEIGHT PER 12Ft (3.66M)
1	2787	116.04 X 25.05 X 1.63	4.300 – 4.800 Kgs

### 25MM – 3 TRACK BOTTOM

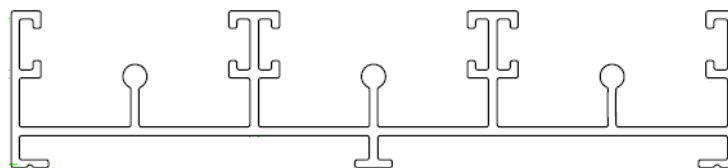

SL.NO	SECTION NO	ITEMS	WEIGHT PER 12Ft (3.66M)
1	2786	116.04 X 25.05 X 1.39	4.300 – 4.800 Kgs

## PART II – STRUCTURAL & ARCHITECTURAL OPENABLE / CASEMENT WINDOW - 'H' & 'Z' SECTION

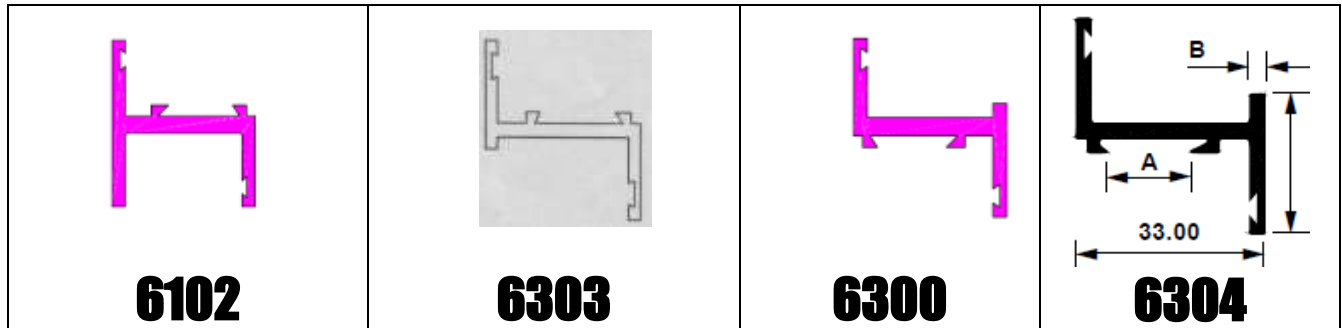

SL.NO	SECTION NO	ITEMS	WEIGHT PER 12Ft (3.66M)
1	6102	38.50 x 23.50 x 2.00	1.792 – 2.000 Kgs
2	6303	32.60 X 23.00 x 2.00	1.900 – 2.100 Kgs
3	6300	32.8 x 23.5x 1.95	1.460 – 1.600 Kgs
4	6304	33.0 x 24.50 x 3.00	2.400 – 2.500 Kgs

### MULLION SECTION

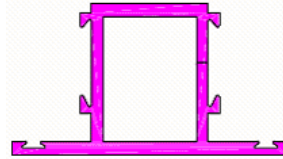

SL.NO	SECTION NO	ITEMS	WEIGHT PER 12Ft (3.66M)
1	6500	59.00 X 33.00 X 2.80	3.900 – 4.000 kGS
2	6502	32.8 x 58.8 x 30 x 2.00	2.975 – 3.200 Kgs

# PART II – STRUCTURAL & ARCHITECTURAL 34MM WINDOW SERIES SPL MULLION SECTION

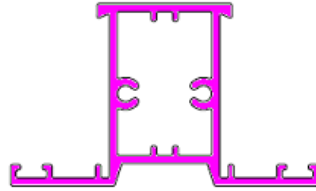

SL.NO	SECTION NO	ITEMS	WEIGHT PER 12Ft (3.66M)
1	6601	34.00 x 57.0 x 25 x 1.5	2.700 – 2.900 Kgs

## SPECIAL H & SPECIAL Z SECTION

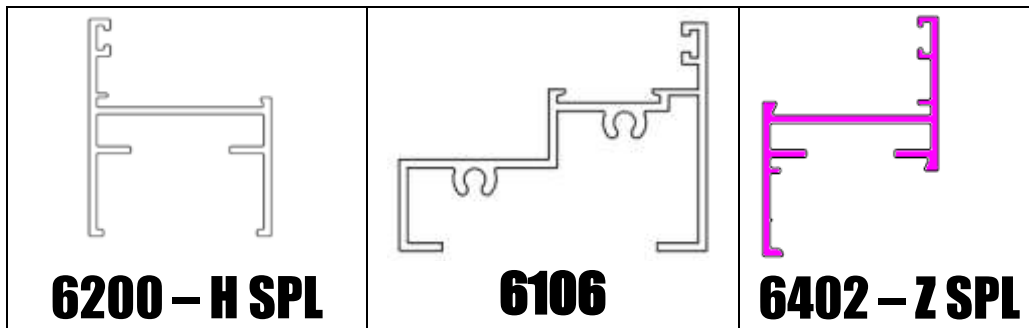

SL.NO	SECTION NO	ITEMS	WEIGHT PER 12Ft (3.66M)
1	6200	43.80 x 34.00 x 1.50	1.745 – 2.000 Kgs
2	6106	62.00 x 45.00 x 1.50	2.500 – 2.700 Kgs
3	6402	43.80 x 34.00 x 1.50	1.680 – 1.900 Kgs



## PART II – STRUCTURAL & ARCHITECTURAL

### 40MM WINDOW SERIES

### 40MM THREE TRACK SIDE & TOP



SL.NO	SECTION NO	ITEMS	WEIGHT PER 12Ft (3.66M)
1	2770	92 X 33.80 X 1.50	4.700 -5.200 KGS

### 40MM THREE TRACK BOTTOM

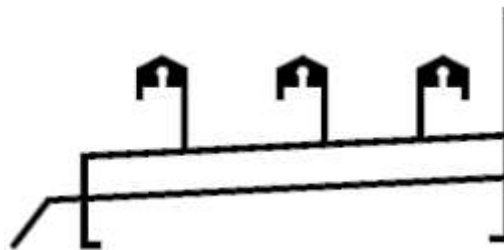

SL.NO	SECTION NO	ITEMS	WEIGHT PER 12Ft (3.66M)
1	2771	107 X 50 X 1.50	6.300 – 6.700 KGS

### 40MM INTERLOCK

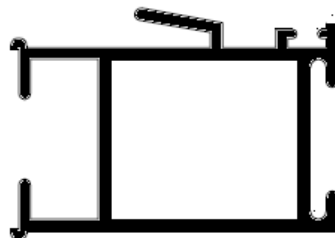

SL.NO	SECTION NO	ITEMS	WEIGHT PER 12Ft (3.66M)
1	2772	40 X 23 X 1.50	2.300 – 2.600 KGS

## PART II – STRUCTURAL & ARCHITECTURAL 40MM WINDOW SERIES

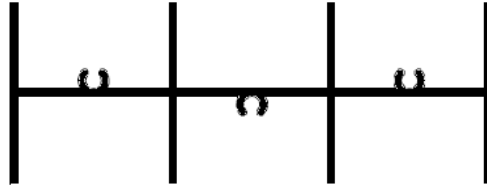

SL.NO	SECTION NO	ITEMS	WEIGHT PER 12Ft (3.66M)
1	2773	92 X 23 X 1.50	3.700 – 4.000 KGS

## 40MM SHUTTER SIDE WITH HANDLE

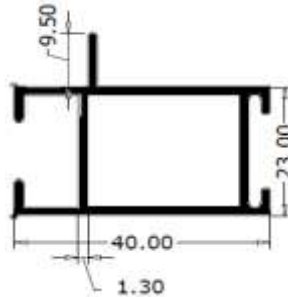

SL.NO	SECTION NO	ITEMS	WEIGHT PER 12Ft (3.66M)
1	2774	40 X 32.50 X 1.30	2.200 – 2.400 KGS

## 40MM SHUTTER TOP

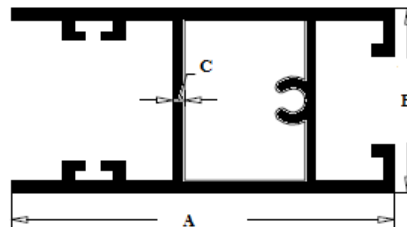

SL.NO	SECTION NO	ITEMS (A x B x C)	WEIGHT PER 12Ft (3.66M)
1	2775	48 X 23 X 1.30	2.000 – 2.300 KGS



# PART II – STRUCTURAL & ARCHITECTURAL 45MM WINDOW SERIES SPL MULLION SECTION

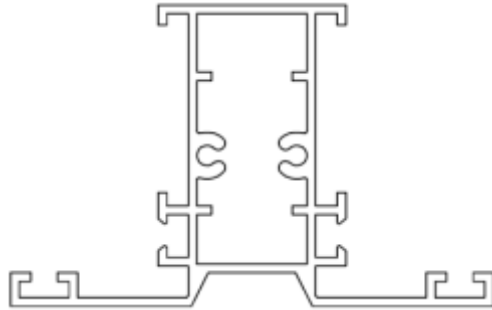

SL.NO	SECTION NO	ITEMS	WEIGHT PER 12Ft (3.66M)
1	6131	72 x 45 x 1.30 MM	3.600 – 3.800 Kgs

## SPL Z-SECTION

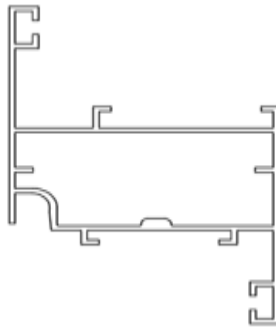

SL.NO	SECTION NO	ITEMS	WEIGHT PER 12Ft (3.66M)
1	6132	46.8 X42.4 X 1.00MM	2.400 – 2.600 Kgs

## SPL H-SECTION - OUTERFRAME

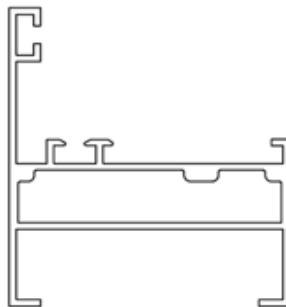

SL.NO	SECTION NO	ITEMS	WEIGHT PER 12Ft (3.66M)
1	6133	50MM X 45MM X 1.1MM	2.400 – 2.600 Kgs

## **PART II – STRUCTURAL & ARCHITECTURAL 45MM WINDOW SERIES SGU CLIP**

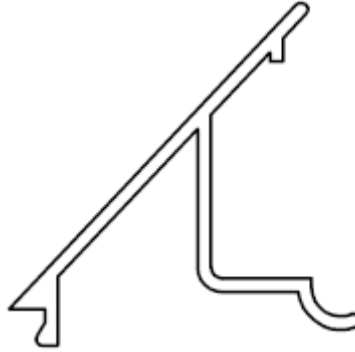

SL.NO	SECTION NO	ITEMS	WEIGHT PER 12Ft (3.66M)
1	6701	29.14 X 28.0 X 1.10MM	0.760 – 0.900 Kgs

## **DGU CLIP**

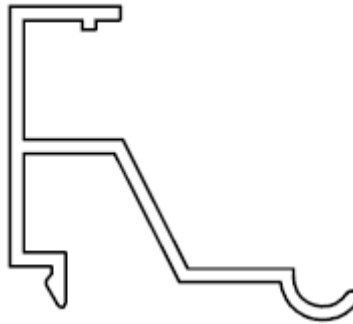

SL.NO	SECTION NO	ITEMS	WEIGHT PER 12Ft (3.66M)
1	6702	28.5 X 25.60 X 1.10MM	0.800 – 0.900 Kgs



# **PART II – STRUCTURAL & ARCHITECTURAL 260MM SERIES SHUTTER**

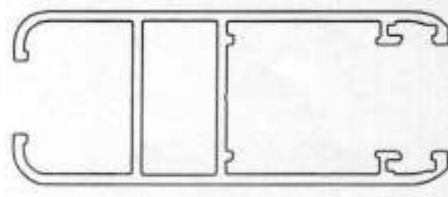

<b>SL.NO</b>	<b>SECTION NO</b>	<b>ITEMS</b>	<b>WEIGHT PER 12Ft (3.66M)</b>
1	2776	65.8 X 26.00 X 1.50MM	3.000 - 3.004 Kgs

## **INTERLOCK**

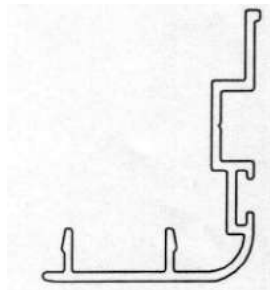

<b>SL.NO</b>	<b>SECTION NO</b>	<b>ITEMS</b>	<b>WEIGHT PER 12Ft (3.66M)</b>
1	2778	29.7 x 38 x 1.3mm	1.150 -1.160Kgs

## PART II – STRUCTURAL & ARCHITECTURAL CURTAIN WALL

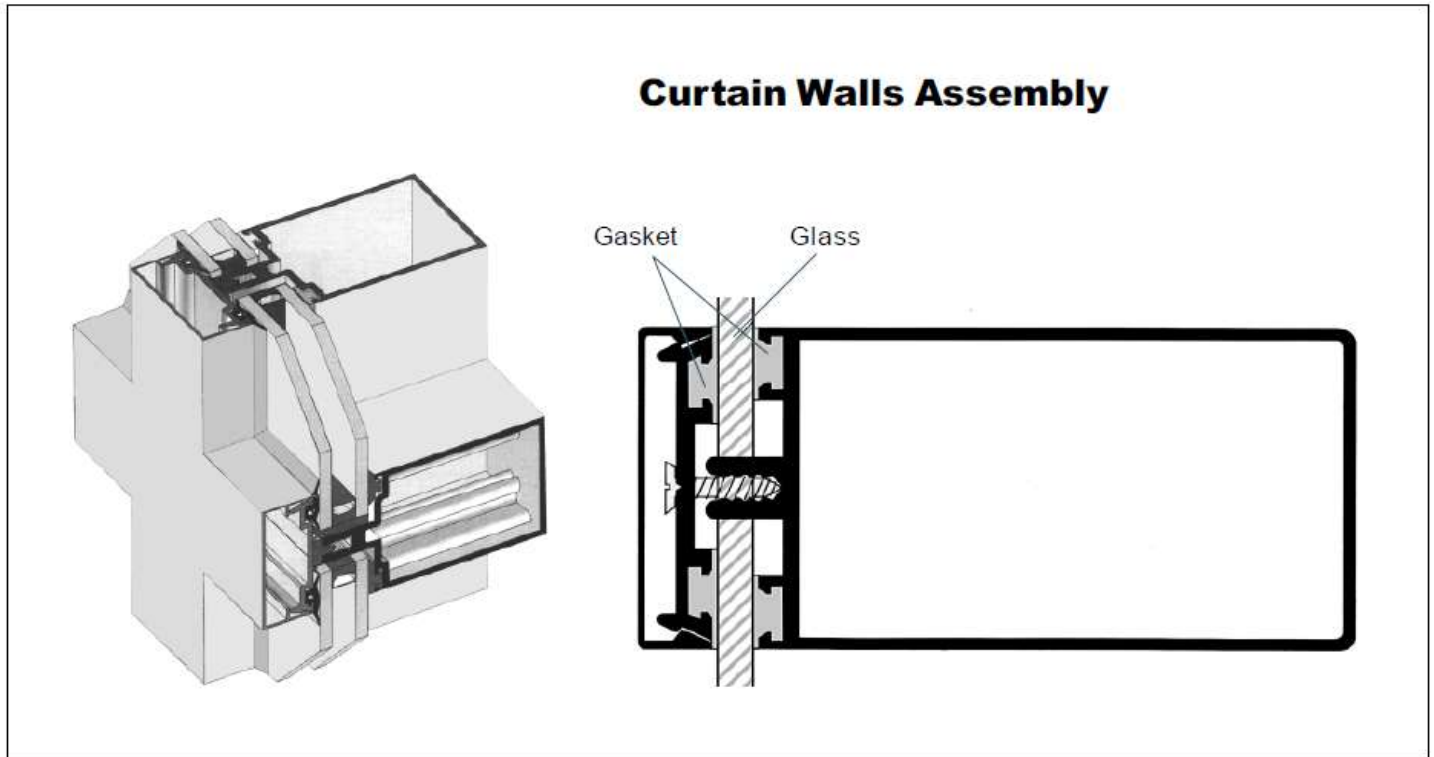

# PART II – STRUCTURAL & ARCHITECTURAL CURTAIN WALL SINGLE LIP SECTION



SL.NO	SECTION NO	ITEMS	WEIGHT PER 12Ft(3.66M)
1	7090	71.3 X 27 X 1.20	2.000 – 2.200

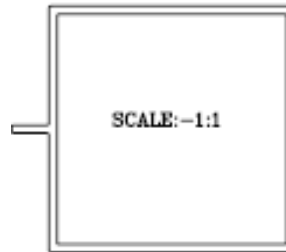

SL.NO	SECTION NO	ITEMS	WEIGHT PER 12Ft(3.66M)
1	7085	53.25 X 46.25 X 1.50	2.800 – 3.000

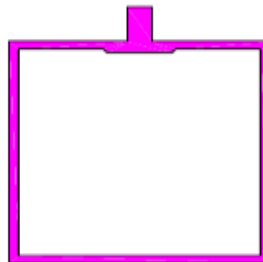

SL.NO	SECTION NO	ITEMS	WEIGHT PER 12Ft(3.66M)
1	7100	74.00 x 58.00 x 1.60	4.627 – 4.800 Kgs
2	7100	74.00 x 58.00 x 2.00	5.627 – 5.800 Kgs



# PART II – STRUCTURAL & ARCHITECTURAL CURTAIN WALL SECTION DGU SUB FRAME

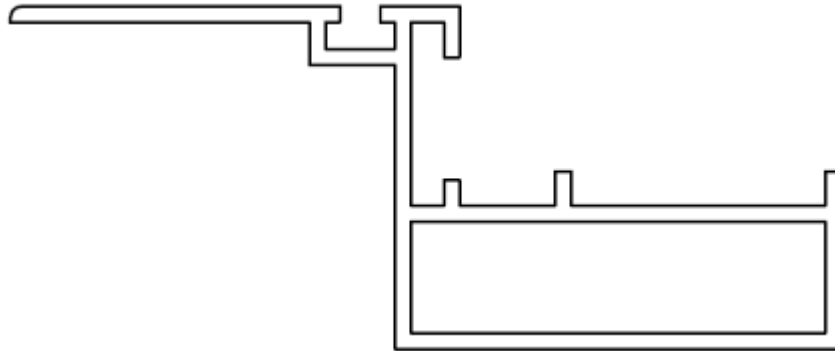

SL.NO	SECTION NO	ITEMS	WEIGHT PER 12Ft(3.66M)
1	7080	36.50 x 24.50 x 1.3MM	2.000 – 2.200 Kgs

# SGU SUB FRAME

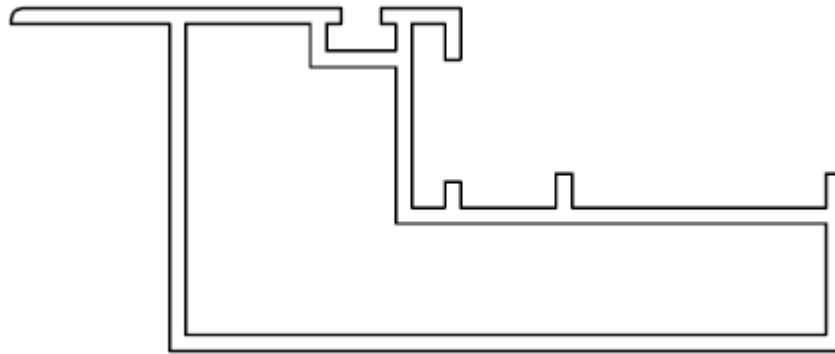

SL.NO	SECTION NO	ITEMS	WEIGHT PER 12Ft(3.66M)
1	7082	55.00 x 24.50 x 1.3MM	2.500 – 2.700 Kgs



## PART II – STRUCTURAL & ARCHITECTURAL CURTAIN WALL SECTION MULLION

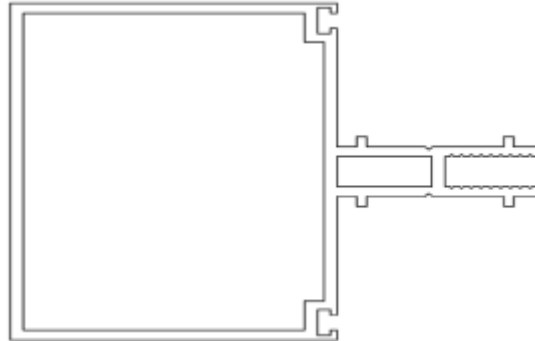

SL.NO	SECTION NO	ITEMS	WEIGHT PER 12Ft(3.66M)
1	7081	81.0 X 67.50 x 50 x 2.00MM	6.100 – 6.400 Kgs
2	7088	56.0 X 67.50 x 25 x 2.00MM	5.100 – 5.400 Kgs

## END MULLION

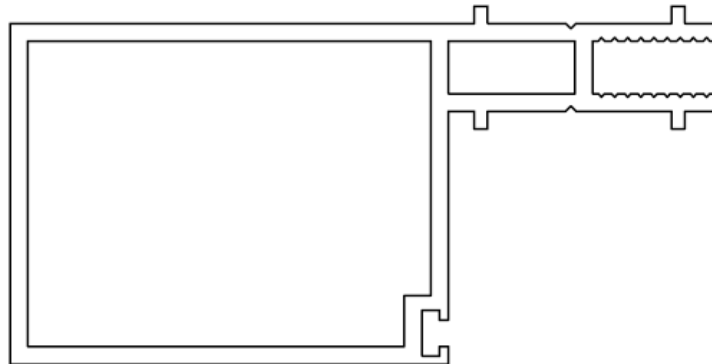

SL.NO	SECTION NO	ITEMS	WEIGHT PER 12Ft(3.66M)
1	7083	81 x 38.75 x 50 x 2.00 MM	4.900 – 5.200 Kgs

## PART II – STRUCTURAL & ARCHITECTURAL CURTAIN WALL SECTION

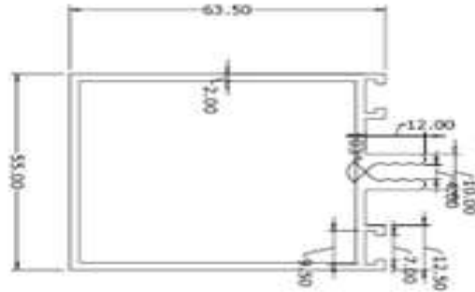

SL.NO	SECTION NO	ITEMS	WEIGHT PER 12Ft(3.66M)
1	7086	63.50 x 55.00 x 2.00	5.400 – 5.800 Kgs

### COVER CAP



SL.NO	SECTION NO	ITEMS	WEIGHT PER 12Ft(3.66M)
1	7070	60 x 20 x 1.40	1.300 Kgs – 1.500 Kgs

### PRESSURE PLATE

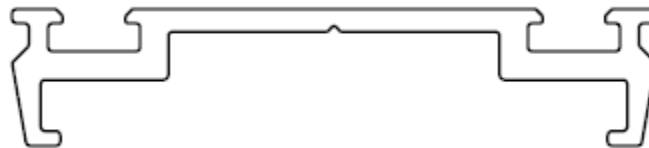

SL.NO	SECTION NO	ITEMS	WEIGHT PER 12Ft(3.66M)
1	7071	57.3 x 12.1 x 2.00	1.910 – 2.100 Kgs

## PART II – STRUCTURAL & ARCHITECTURAL NORTHLIGHT GLAZING BAR

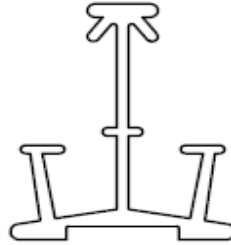

SL.NO	SECTION NO	ITEMS	WEIGHT PER 12Ft(3.66M)
1	7101	25.50 x 35.00 x 1.50	1.900 – 2.100 Kgs

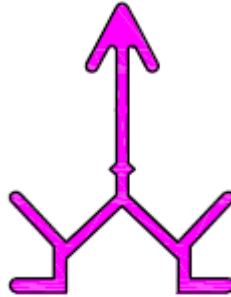

SL.NO	SECTION NO	ITEMS	WEIGHT PER 12Ft(3.66M)
1	7104	28.00 x 35.00 x 1.70	1.800 – 2.000 Kgs

### SHOE PLATE

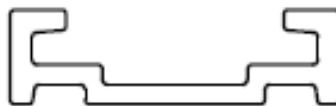

SL.NO	SECTION NO	ITEMS	WEIGHT PER 12Ft (3.66M)
1	7105	32.00 x 9.50 x 2.00	1.200 – 1.400 Kgs

## PART II – STRUCTURAL & ARCHITECTURAL KITCHEN CABINET SECTION

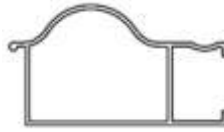

SL.NO	SECTION NO	ITEMS	WEIGHT PER 12Ft (3.66M)
1	3201	40.00 x 22.10 x 1.00	0.750 – 0.850 Kgs

### SPL KITCHEN CABINET SECTION

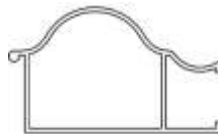

SL.NO	SECTION NO	ITEMS	WEIGHT PER 12Ft (3.66M)
1	3207	36.00 x 23.00 x 1.00	0.750 – 0.850 Kgs

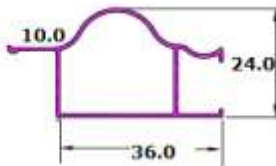

SL.NO	SECTION NO	ITEMS	WEIGHT PER 12Ft (3.66M)
1	3205 *	36.00 x 24.00 x 1.00	0.750 – 0.850 Kgs

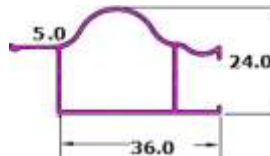

SL.NO	SECTION NO	ITEMS	WEIGHT PER 12Ft (3.66M)
1	3209	36.00 x 24.00 x 0.64	0.750 – 0.850 Kgs



SL.NO	SECTION NO	ITEMS	WEIGHT PER 12Ft (3.66M)
1	3208	49.5 x 20.6 x 0.65	0.900 – 1.00 Kgs

## PART II – STRUCTURAL & ARCHITECTURAL KITCHEN CABINET BIG W/O LIP



SL.NO	SECTION NO	ITEMS	WEIGHT PER 12Ft (3.66M)
1	3210	63.5 x 25.10 x 0.50	1.000 – 1.100 Kgs

## KITCHEN CABINET BIG WITH LIP



SL.NO	SECTION NO	ITEMS	WEIGHT PER 12Ft (3.66M)
1	3211	48.80 x 20.40 x 0.66	1.000 – 1.100 Kgs

## SHOW CASE SECTION



SL.NO	SECTION NO	ITEMS	WEIGHT PER 12Ft (3.66M)
1	3200	66.00 x 32.30 x 0.80	1.500 – 1.700 Kgs
2	3202	66.00 x 32.30 x 0.95	1.800 – 2.000 Kgs
3	3213	66.30 x 32.10 x 0.70	1.100 – 1.200 Kgs

## GULF KITCHEN CABINET – SQUARE TYPE

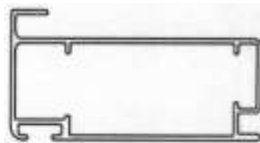

SL.NO	SECTION NO	ITEMS	WEIGHT PER 12Ft (3.66M)
1	3214	42.00 x 21.50 x 0.70	1.000 – 1.200 Kgs

## GULF KITCHEN CABINET – ROUND TYPE

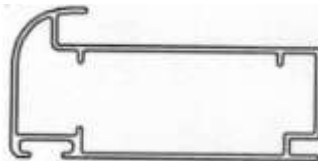

SL.NO	SECTION NO	ITEMS	WEIGHT PER 12Ft (3.66M)
1	3215	42.00 x 20.50 x 0.70	1.000 – 1.200 Kgs

\* EXCLUSIVE



# PART III - MOULDINGS & TRANSPORT

## MAJOR APPLICATIONS



## PART III – MOULDINGS & TRANSPORT

### HALF ROUND BEADING

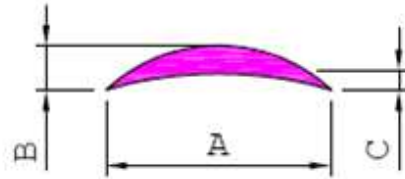

SL.NO	SECTION NO	ITEMS (A X B X C)	WEIGHT PER 12Ft (3.66M)
1	5001	24.00 x 3.18 x 1.16	0.380 – 0.500 Kgs
2	5003	25.15 x 4.60 x 1.70	0.549 – 0.650 Kgs
3	5007	22.71 x 6.70 x 2.60	0.480 – 0.600 Kgs

### FLAT ROUND EDGE



SL.NO	SECTION NO	ITEMS	WEIGHT PER 12Ft (3.66M)
1	5010	25.40 x 2.495	0.600 – 0.750 Kgs
2	5011	25.40 x 3.098	0.750 – 0.900 Kgs

### SHOW BEADING



SL.NO	SECTION NO	ITEMS	WEIGHT PER 12Ft (3.66M)
1	5017	24.99 x 1.60	0.280 – 0.400 Kgs
2	5020	24.99 x 3.71	0.600 – 0.800 Kgs

### RUBRAIL BEADING



SL.NO	SECTION NO	ITEMS	WEIGHT PER 12Ft (3.66M)
1	5050	52.00 x 4.00	1.700 – 1.900 Kgs

## PART III – MOULDINGS & TRANSPORT RUBY BEADING



SL.NO	SECTION NO	ITEMS	WEIGHT PER 12Ft (3.66M)
1	5225	28.60 x 4.40	0.525- 0.600 Kgs



SL.NO	SECTION NO	ITEMS	WEIGHT PER 12Ft (3.66M)
1	5226	19.50x7.03 x 1.70	0.540 -0.640 Kgs

## KEY GOLA



SL.NO	SECTION NO	ITEMS	WEIGHT PER 12Ft (3.66M)
1	5100	29.69 x 10.41 x 4.44 x 0.7	0.280 – 0.400 Kgs
2	5101	29.80 x 10.7 x 5.00 x 1.10	0.500 – 600 Kgs
3	5102	29.00 x 10.3 x 5.50 x 1.40	0.600 – 0.750 Kgs



SL.NO	SECTION NO	ITEMS	WEIGHT PER 12Ft (3.66M)
1	5103	50.00 x 9.5 x 11.00 x 1.23	1.100 – 1.300 Kgs
2	5104	48.48 x 11.31 X 7.17 X 1.00	0.650 – 0.800 Kgs

## FOOT BOARD BEADING



SL.NO	SECTION NO	ITEMS	WEIGHT PER 12Ft (3.66M)
1	5201	31.75x2.35x1.2 x 2.44x2.44	0.570 – 0.750 Kgs
2	5202	31.75 x 4.00 x 1.60 x 2.44	0.950 – 1.200 Kgs



## PART III – MOULDINGS & TRANSPORT

### 1½" STEP EDGE



SL.NO	SECTION NO	ITEMS	WEIGHT PER 12Ft (3.66M)
1	5210	38.5 x 12.0 x 2.00	0.750 – 0.900 Kgs



SL.NO	SECTION NO	ITEMS	WEIGHT PER 12Ft (3.66M)
1	5212	38.5 X 16.4 X 2.90	1.250 – 1.400 Kgs

### 2¼" STEP EDGE



SL.NO	SECTION NO	ITEMS	WEIGHT PER 12Ft (3.66M)
1	5220	57.15 x 15.88 x 2.1	1.232 – 1.400 Kgs
2.	5221	57.15 x15.88 x 2.5	1.350 - 1.550 Kgs

### ROOF LATERAL BEADING



SL.NO	SECTION NO	ITEMS	WEIGHT PER 12Ft (3.66M)
1	5215	38.00 x 7.80 x 1.80	1.100 – 1.300Kgs

### J WATER CHANNEL



SL.NO	SECTION NO	ITEMS	WEIGHT PER 12Ft (3.66M)
1	5300	25.4 x 12.7 x 1.46	0.596 – 0.750 Kgs
2	5301	24.0 x 15.6 x 2.11	0.900 – 1.100 Kgs
3	5302	36.2 x 18.0 x 1.31	0.750 – 0.950 Kgs
4	5303	28.0 x 18.0 x 1.30	0.640 – 0.800 Kgs
5	5304	25.7 x 19.6 x 2.60	1.200 – 1.500 Kgs

## PART III – MOULDINGS & TRANSPORT WIRING CHANNEL



SL.NO	SECTION NO	ITEMS	WEIGHT PER 12Ft (3.66M)
1	5330	40 X 14.20 X 1.5	0.850 – 1.000 Kgs

### 5" SHOW BEADING



SL.NO	SECTION NO	ITEMS	WEIGHT PER 12Ft (3.66M)
1	5335	127 x 4.98 x 1.25	2.600 – 2.800 Kgs

### SPL BUS WINDOW H

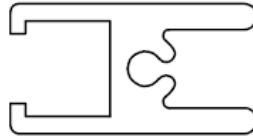

SL.NO	SECTION NO	ITEMS	WEIGHT PER 12Ft (3.66M)
1	5230	28.40 X 15 X 2.00	2.000 – 2.200 Kgs

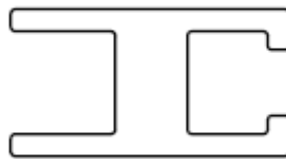

SL.NO	SECTION NO	ITEMS	WEIGHT PER 12Ft (3.66M)
1	5432	24.00 x 12.65 X 1.90	1.500 – 1.700 Kgs

## PART III – MOULDINGS & TRANSPORT

### J.K.DOOR SECTION

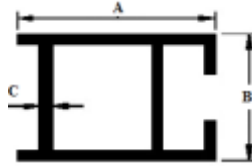

SL.NO	SECTION NO	ITEMS	WEIGHT PER 12Ft (3.66M)
1	5466	47.30 x 27.80 X 3.00	4.050 – 4.250Kgs

### T.V.S.WATER CHANNEL



SL.NO	SECTION NO	ITEMS	WEIGHT PER 12Ft (3.66M)
1	5310	50.0 x 23.8 X 0.7	0.700 – 0.850 Kgs
2	5311	50.0 x 23.8 x 1.2	1.100 -1.300 Kgs

### TIE BAR

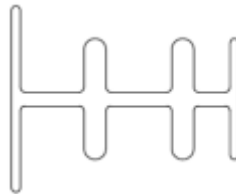

SL.NO	SECTION NO	ITEMS	WEIGHT PER 12Ft (3.66M)
1	5416	46.40 X 38 x 2.80	4.200 – 4.500 Kgs

### VOLVO TIE BAR

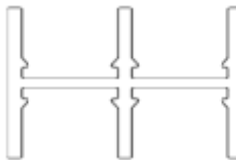

SL.NO	SECTION NO	ITEMS	WEIGHT PER 12Ft (3.66M)
1	5417	38.80 X 39.6 x 2.40	3.700- 3.900 Kgs

### TIE BAR

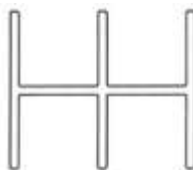

SL.NO	SECTION NO	ITEMS	WEIGHT PER 12Ft (3.66M)
1	5418	36.0 X 31.0 X 1.70	2.000 – 2.300 Kgs

# PART III – MOULDINGS & TRANSPORT

## MAZDA BEADING

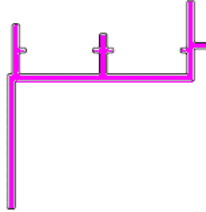

SL.NO	SECTION NO	ITEMS	WEIGHT PER 12Ft (3.66M)
1	5400	43.5 x 46.2 x 1.55	1.710 – 1.900 Kgs
2	5401	43.5 x 46.2 x 1.82	2.000 – 2.150 Kgs
3	5402	43.5 x 46.2 x 2.02	2.200 – 2.450 Kgs

## SPL MAZDA BEADING



SL.NO	SECTION NO	ITEMS	WEIGHT PER 12Ft (3.66M)
1	5404	47.4 x 52.7 x 3.00	3.200 – 3.500 Kgs

## DOUBLE LEG MAZDA

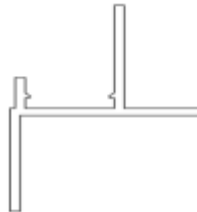

SL.NO	SECTION NO	ITEMS	WEIGHT PER 12Ft (3.66M)
1	5415	37.50 x 30.00 x 1.00	2.100 – 2.250 Kgs

## FLUTED CHANNEL



SL.NO	SECTION NO	ITEMS	WEIGHT PER 12Ft (3.66M)
1	5406	32.50 x 12.00 x 1.5	1.200 – 1.450 Kgs

## PART III – MOULDINGS & TRANSPORT GRILL BEADING



SL.NO	SECTION NO	ITEMS	WEIGHT PER 12Ft (3.66M)
1	5410	22.7 x 22.7 x 0.765	0.475 – 0.550 Kgs
2	5411	22.7 x 22.7 x 0.885	0.550 – 0.700 Kgs
3	5412	22.7 x 22.7 x 1.229	0.750 – 0.900 Kgs

## D.C.M 'E' BEADING

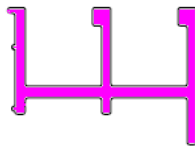

SL.NO	SECTION NO	ITEMS	WEIGHT PER 12Ft (3.66M)
1	5420	31.2 x 22.5 x 1.545	1.500 – 1.700 Kgs

## WINDOW FRAME

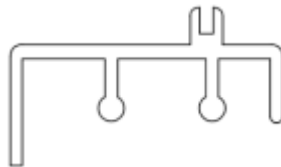

SL.NO	SECTION NO	ITEMS	WEIGHT PER 12Ft (3.66M)
1	5231	47 X 21 X 2.00	2.600 – 2.800 Kgs

## WIPER 'H' SECTION



SL.NO	SECTION NO	ITEMS	WEIGHT PER 12Ft (3.66M)
1	5430	17.3 x 8.5 x 1.122	0.550 – 0.750 Kgs

## MICRO E-SECTION



SL.NO	SECTION NO	ITEMS	WEIGHT PER 12Ft (3.66M)
1	5435	25.4 x 14.6 x 0.5	1.950 – 2.100 Kgs

# PART III – MOULDINGS & TRANSPORT

## SPL VOLVO BEADING

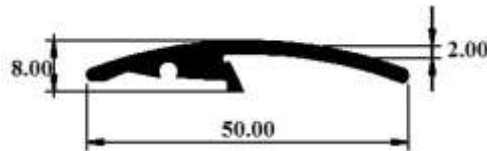

SL.NO	SECTION NO	ITEMS	WEIGHT PER 12Ft (3.66M)
1	5445	50 X 8.00 X 3.00	1.300 – 1.500Kgs

## VOLVO BEADING



SL.NO	SECTION NO	ITEMS	WEIGHT PER 12Ft (3.66M)
1	5440	49.5 x 7.69 x 2.00	1.350 – 1.450 Kgs
2	5440	49.5 x 7.69 x 2.61	1.500 – 1.700 Kgs
3	5441	50.0 x 10.50 x 3.70	2.000 – 2.300 Kgs

## D.C.M.SHOW BEADING



SL.NO	SECTION NO	ITEMS	WEIGHT PER 12Ft (3.66M)
1	5450	39.3 x 7.7 x 15 x 1.7	1.030 – 1.200 Kgs

## WALL FACING



SL.NO	SECTION NO	ITEMS	WEIGHT PER 12Ft (3.66M)
1	5110	50.5 x 4.00 x 0.90	0.540 – 0.750 Kgs



# PART III – MOULDINGS & TRANSPORT SMALL HITECH BEADING

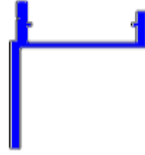

SL.NO	SECTION NO	ITEMS	WEIGHT PER 12Ft (3.66M)
1	5460	41 x 20.75 x 1.50	1.098 – 1.200 Kgs
2	5464	41.2 x 20.5 x 2.00	1.360 – 1.560 Kgs

## SION BEADING



SL.NO	SECTION NO	ITEMS	WEIGHT PER 12Ft (3.66M)
1	5461	90.5 x 6.0 x 12.62 x 1.00	0.900 – 1.200 Kgs



SL.NO	SECTION NO	ITEMS	WEIGHT PER 12Ft (3.66M)
1	5462	126.3 x 8.9 x 18.60 x 0.80	1.500 – 1.700 Kgs

## AMBASSADOR BEADING

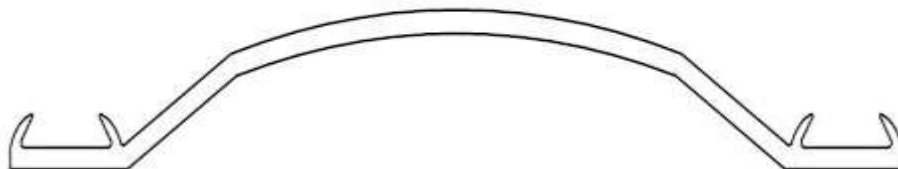

SL.NO	SECTION NO	ITEMS	WEIGHT PER 12Ft (3.66M)
1	5465	128 x 14.80 X 2.2	3.000 – 3.300 Kgs

# PART III – MOULDINGS & TRANSPORT

## VOLVO LUGGAGE HINGES



SL.NO	SECTION NO	ITEMS	WEIGHT PER 12Ft (3.66M)
1	5451	30.2 x 27 x 3 MM	2.400 Kgs

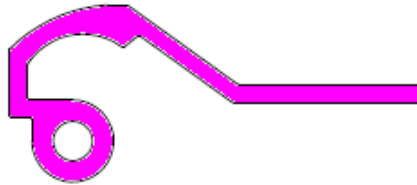

SL.NO	SECTION NO	ITEMS	WEIGHT PER 12Ft (3.66M)
1	5452	70.7 x 30.2 x 3 MM	4.200 Kgs

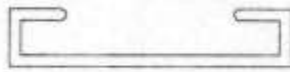

SL.NO	SECTION NO	ITEMS	WEIGHT PER 12Ft (3.66M)
1	5467	24.5 x 5.00 x 1 MM	4.000- 4.300 Kgs

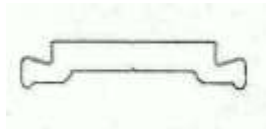

SL.NO	SECTION NO	ITEMS	WEIGHT PER 12Ft (3.66M)
1	5468	19.3x4.10x 2.65mm	5.000 – 5.200Kgs





# PART IV – INDUSTRIAL & GENERAL MISCELLANEOUS

## MAJOR APPLICATIONS





## PART IV – INDUSTRIAL & GENERAL MISCELLANEOUS TABLE SECTION

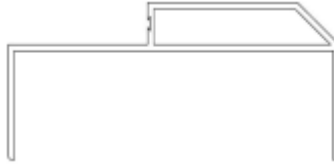

SL.NO	SECTION NO	ITEMS	WEIGHT PER 12Ft (3.66M)
1	3367	95.00 x 45.00 x 1.75 MM	4.000 – 4.200 Kgs

### OMEGA SECTION

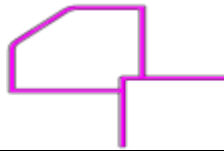

SL.NO	SECTION NO	ITEMS	WEIGHT PER 12Ft (3.66M)
1	3203	32.40 x 40.00 x 65.00 x 1.8	3.500 – 3.700 Kgs

### DELTA SECTION



SL.NO	SECTION NO	ITEMS	WEIGHT PER 12Ft (3.66M)
1	3204	90.00 x 34.60 x 40.00 x 1.80	3.800 – 4.000 Kgs
2	3206	84.00 x 34.00 x 40.00 x 5.00	4.000 - 4.300 Kgs

### TARPAULIN SECTION

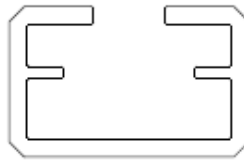

SL.NO	SECTION NO	ITEMS	WEIGHT PER 12Ft (3.66M)
1	3219	40.00 x 25.00 x 3.00	3.250 – 3.400 Kgs

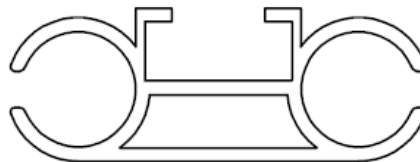

SL.NO	SECTION NO	ITEMS	WEIGHT PER 12Ft (3.66M)
1	3377	46.40 x 17.00 x 1.50	2.100 – 2.300 Kgs



# PART IV – INDUSTRIAL & GENERAL MISCELLANEOUS A/C GRILL SECTION

<p>3301 0.560(12 feet)</p>	<p>3303 0.320(12 feet)</p>	<p>3304 0.360(12 feet)</p>
<p>3305 0.330(12 feet)</p>	<p>3306 0.450(12 feet)</p>	<p>3307 0.820(12 feet)</p>
<p>3308 2.000(12 ft)</p>	<p>3309 2.300(12 feet )</p>	
<p>3310 1.800 (12 feet )</p>		



# PART IV – INDUSTRIAL & GENERAL MISCELLANEOUS A/C GRILL SECTION

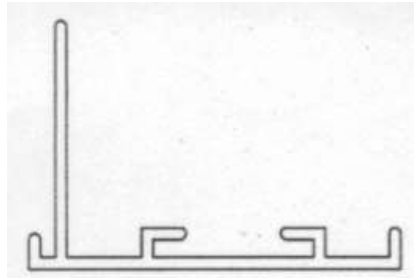

SL.NO	SECTION NO	ITEMS	WEIGHT PER 12Ft (3.66M)
1	3311	32.40 x 21.00 x 1.00 MM	0.670 – 0.800 Kgs

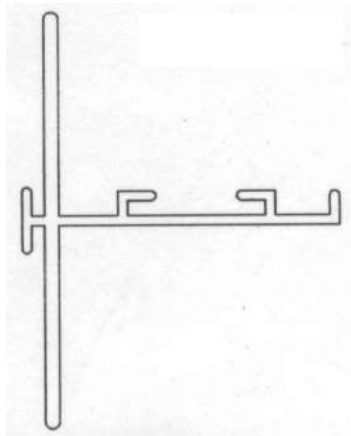

SL.NO	SECTION NO	ITEMS	WEIGHT PER 12Ft (3.66M)
1	3312	32.40 x 42.80 x 1.50 MM	1.130 – 1.250 Kgs



# PART IV – INDUSTRIAL & GENERAL MISCELLANEOUS MODULAR SHOWCASE SECTION

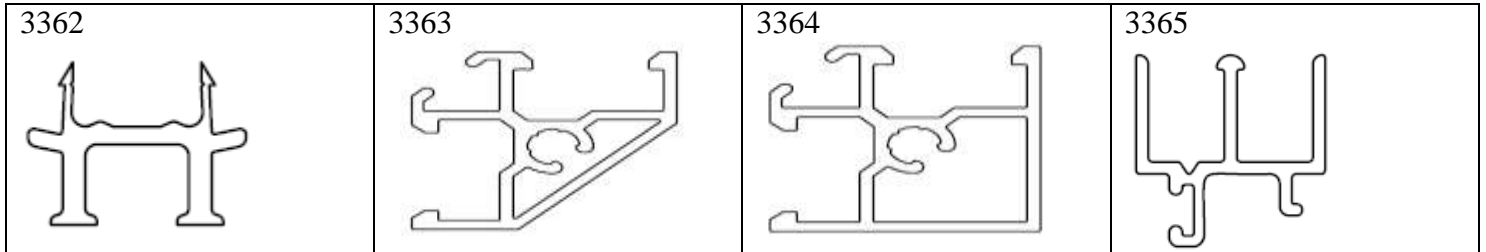

SL.NO	SECTION NO	ITEMS	WEIGHT PER 12Ft (3.66M)
1	3362	19 x 14 x 15 x 1.6MM	0.647 – 0.800 Kgs
2	3363	30 x 30 x 30 x 30MM	2.118 – 2.300 Kgs
3	3364	26.75 x 9.15 x 1.9MM	0.902 – 1.200 Kgs
4	3365	20 x 20.3 x 1.3 MM	0.933 – 1.200 Kgs

## RAIL SECTION

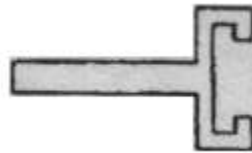

SL.NO	SECTION NO	ITEMS	WEIGHT PER 12Ft (3.66M)
1	3360	21.00X13.20X3.00X4.90	3.000 – 3.200 Kgs

# PART IV – INDUSTRIAL & GENERAL MISCELLANEOUS FLYSCREEN NETLON SECTION

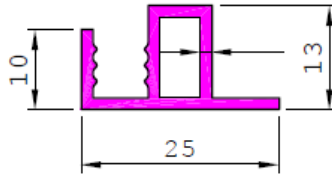

SL.NO	SECTION NO	ITEMS	WEIGHT PER 12Ft (3.66M)
1	3358	25 X 10 X 1.30	0.850 - 0.900
1	3359	25 X 10 X 1.10	0.700 - 0.800



SL.NO	SECTION NO	ITEMS	WEIGHT PER 12Ft (3.66M)
1	3361	20.3 X 10.2 X 0.60mm	0.400 - 0.450 Grms

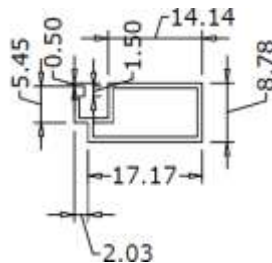

SL.NO	SECTION NO	ITEMS	WEIGHT PER 12Ft (3.66M)
1	3381	17.17 X 8.78	0.400 - 0.550 Grms

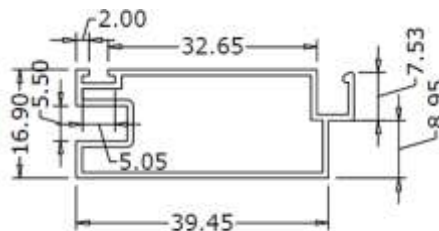

SL.NO	SECTION NO	ITEMS	WEIGHT PER 12Ft (3.66M)
1	3380	39.45 X 16.90	0.400 - 0.550 Grms



## PART IV – INDUSTRIAL & GENERAL MISCELLANEOUS FLYSCREEN NETLON SECTION

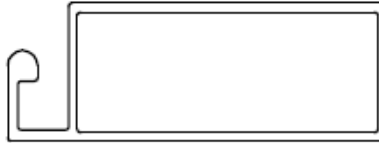

SL.NO	SECTION NO	ITEMS	WEIGHT PER 12Ft (3.66M)
1	3404	37.8 X 13.70 X 0.87MM	0.950 – 1.000 Kgs

### BULLET SECTION



SL.NO	SECTION NO	ITEMS	WEIGHT PER 12Ft (3.66M)
1	3382	48 X 17 X 11.00MM	6.00 – 6.50 Kgs

### DISPLAY SECTION



SL.NO	SECTION NO	ITEMS	WEIGHT PER 12Ft (3.66M)
1	3383	100 X 17 X 2.00MM	5.500 -6.000Kgs



SL.NO	SECTION NO	ITEMS	WEIGHT PER 12Ft (3.66M)
1	3384	33 x 7 x 1.20MM	0.750 – 0.850Kgs

## PART IV – INDUSTRIAL & GENERAL MISCELLANEOUS RACK SECTION

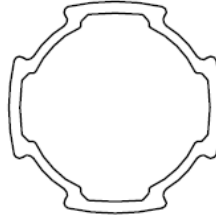

SL.NO	SECTION NO	ITEMS	WEIGHT PER 12Ft (3.66M)
1	3385*	28 x 28 x 1.50MM	1.300 – 1.340Kgs



SL.NO	SECTION NO	ITEMS	WEIGHT PER 12Ft (3.66M)
1	3389*	28 x 24 x 1.50MM	2.500 – 3.000 Kgs

## MODULAR SECTION



SL.NO	SECTION NO	ITEMS	WEIGHT PER 12Ft (3.66M)
1	3386	76 x 22 x 1.20MM	2.000 Kgs



SL.NO	SECTION NO	ITEMS	WEIGHT PER 12Ft (3.66M)
1	3387	50.06 x 22 x 1.50MM	1.520 Kgs

\*Exclusive DIE



## PART IV – INDUSTRIAL & GENERAL MISCELLANEOUS PHOTO FRAME SECTION



SL.NO	SECTION NO	ITEMS	WEIGHT PER 12Ft (3.66M)
1	3388	15.4 x 25.0 x 1.00mm	0.600 Kgs

## SCAFOLD SECTION

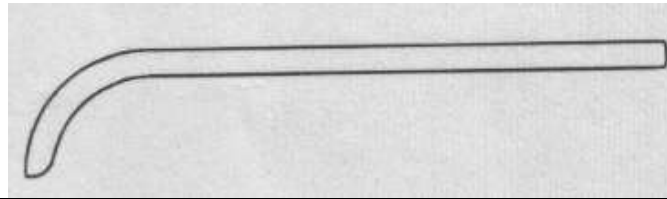

SL.NO	SECTION NO	ITEMS	WEIGHT PER 12Ft (3.66M)
1	3366	62.00 X 12.00 X 2.50	1.700-1.900 Kgs



SL.NO	SECTION NO	ITEMS	WEIGHT PER 12Ft (3.66M)
1	3368	50.80 X 2.50 MM	3.800 Kgs



SL.NO	SECTION NO	ITEMS	WEIGHT PER 12Ft (3.66M)
1	3370	100.30 x 33.50 x 1.70mm	3.550 Kgs

# PART IV – INDUSTRIAL & GENERAL MISCELLANEOUS

## VERTICAL CHANNEL



SL.NO	SECTION NO	ITEMS	WEIGHT PER 15Ft
1	3390*	44 x 25 x2.35MM	1.285 – 1.500 Kgs



SL.NO	SECTION NO	ITEMS	WEIGHT PER 15Ft
1	3391*	43.50 x 25.7 x0.87MM	1.295 – 1.500 Kgs

## ROLLER BOTTOM

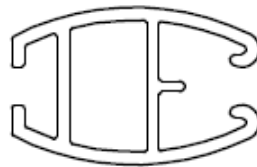

SL.NO	SECTION NO	ITEMS	WEIGHT PER 15Ft
1	3392*	25.00 x 16.0 x1.30MM	1.375 – 1.500 Kgs

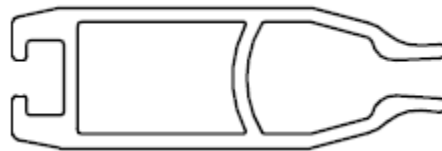

SL.NO	SECTION NO	ITEMS	WEIGHT PER 12Ft (3.66M)
1	3406*	37.80 x 12.20 x1.20MM	1.675- 1.810 Kgs

\*Exclusive DIE

# PART IV – INDUSTRIAL & GENERAL MISCELLANEOUS

## ZEBRA PLUMET



SL.NO	SECTION NO	ITEMS	WEIGHT PER 15Ft
1	3393*	80.00 x 67.50 x 0.90MM	2.225 – 2.375 Kgs
2	3408*	80.00 x 67.50 x 0.90MM	2.100 – 2.400 Kgs

## ROLLER TUBE



SL.NO	SECTION NO	ITEMS	WEIGHT PER 15Ft
1	3394*	OD 39.00 x ID 37.8 x0.60MM	1.150 – 1.500 Kgs



SL.NO	SECTION NO	ITEMS	WEIGHT PER 15Ft
1	3401*	OD 39.00 x ID 37.40 x0.80MM	1.360 – 1.600 Kgs



SL.NO	SECTION NO	ITEMS	WEIGHT PER 15Ft
1	3407*	OD 38.70 x ID 37.4 x0.65MM	1.160 -1.500 Kgs

\*Exclusive DIE



## PART IV – INDUSTRIAL & GENERAL MISCELLANEOUS

### ZEBRA BOTTOM – PART I



SL.NO	SECTION NO	ITEMS	WEIGHT PER 15Ft
1	3395*	Ø15 x 1.40MM	0.775 – 0.900 Kgs

### ZEBRA BOTTOM PART -II



SL.NO	SECTION NO	ITEMS	WEIGHT PER 15Ft
1	3400*	11.60 x 25.68 x1.00MM	0.785 – 0.810Kgs

### STAR ROD

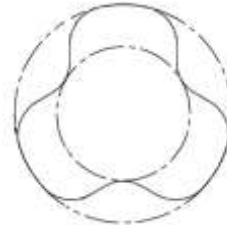
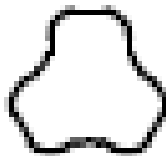

SL.NO	SECTION NO	ITEMS	WEIGHT PER 15Ft
1	3396*	OD5.6 x ID3.2 X 2.65MM	0.210 – 0.250 Kgs
2	3396*	OD5.6 x ID3.2 X 2.65MM	0.200 – 0.250 Kgs

\*Exclusive DIE



## PART IV – INDUSTRIAL & GENERAL MISCELLANEOUS

### HEXAGONAL TUBE



SL.NO	SECTION NO	ITEMS	WEIGHT PER 15Ft
1	3397*	7.00 x 7.96 x1.20MM	0.300 – 0.400 Kgs

### M TRACK

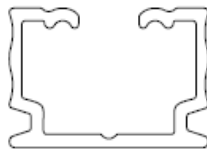

SL.NO	SECTION NO	ITEMS	WEIGHT PER 15Ft
1	3398*	23.00 x 16.00 x1.54MM	1.200 – 1.300 Kgs

### ROMAN CHANNEL

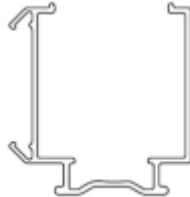

SL.NO	SECTION NO	ITEMS	WEIGHT PER 15Ft
1	3399*	29.60 x 35.70 x1.00MM	1.520 – 1.625 Kgs

\*Exclusive DIE



# PART IV – INDUSTRIAL & GENERAL MISCELLANEOUS

## FIFA WORLD CUP SECTION



SL.NO	SECTION NO	ITEMS	WEIGHT PER 15Ft
1	3402	8.00 x 13.00 x 1.20MM	0.410 - 0.420 Kgs



SL.NO	SECTION NO	ITEMS	WEIGHT PER 15Ft
1	3403	11.40 x 28.00 x 1.30MM	0.940 - 0.950 Kgs

## TELEPHONE ADAPTOR



SL.NO	SECTION NO	ITEMS	WEIGHT PER 12Ft (3.66M)
1	3405	30 X 45 X 2.50MM	3.320 – 4.000 Kgs



## PART IV – INDUSTRIAL & GENERAL MISCELLANEOUS TYRE SECTION



SL.NO	SECTION NO	ITEMS	WEIGHT PER 12Ft (3.66M)
1	3373	86 X 41 X 2.00	3.500 Kgs
2	3374	73 X 31 X 2.00	3.100 Kgs



SL.NO	SECTION NO	ITEMS	WEIGHT PER 12Ft (3.66M)
1	3371	59.96 X 43.20 X 3.00	2.45 Kgs
2	3375	53.3 X 31.80 X 3.00	2.00 Kgs

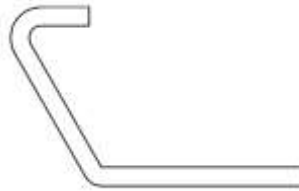

SL.NO	SECTION NO	ITEMS	WEIGHT PER 12Ft (3.66M)
1	3372	49.01 x 39.00 x 3.00	2.52 Kgs
2	3376	48.01 X 29.00 X 3.00	2.20 Kgs

**Breathe Easy !**

**Its ALUMINIUM ! SAVE TREES !**



**Aluminium in your daily Life**

Architecture, Transport, Electrical/Electronics, Fabrication & Lighting.  
While moving from Cradle to grave – consumes less energy and keeps the air clean.

**TALCO ALUMINIUM COMPANY**, a clean companion in your life.

Green Initiatives that help build the lungs of the environment

---

**TALCO ALUMINIUM COMPANY**

**An ISO 9001:2008 Certified Company**

**MANUFACTURER OF ALUMINIUM EXTRUSION PROFILES**

Regd. Office: D85/1, GNT Road, Ponniammanmedu, Madhavaram Chennai - 600 110

(Landmark: OPP. Road of HP PETROL BUNK and TRUCK TERMINAL)

Phone: (91)-44-23468559 / 23468533 / 23468907 , Telefax: (91)-44-23468906

E-mail: [talcochennai@talco.in](mailto:talcochennai@talco.in)